

Grizzly *Industrial, Inc.*®

MODEL G1021X 15" EXTREME SERIES PLANER OWNER'S MANUAL



COPYRIGHT © MARCH, 2006 BY GRIZZLY INDUSTRIAL, INC., REVISED OCTOBER, 2007 (TS)
**WARNING: NO PORTION OF THIS MANUAL MAY BE REPRODUCED IN ANY SHAPE
OR FORM WITHOUT THE WRITTEN APPROVAL OF GRIZZLY INDUSTRIAL, INC.**
#JK7980 PRINTED IN TAIWAN

 **WARNING!**

This manual provides critical safety instructions on the proper setup, operation, maintenance and service of this machine/equipment.

Failure to read, understand and follow the instructions given in this manual may result in serious personal injury, including amputation, electrocution or death.

The owner of this machine/equipment is solely responsible for its safe use. This responsibility includes but is not limited to proper installation in a safe environment, personnel training and usage authorization, proper inspection and maintenance, manual availability and comprehension, application of safety devices, blade/cutter integrity, and the usage of personal protective equipment.

The manufacturer will not be held liable for injury or property damage from negligence, improper training, machine modifications or misuse.

 **WARNING!**

Some dust created by power sanding, sawing, grinding, drilling, and other construction activities contains chemicals known to the State of California to cause cancer, birth defects or other reproductive harm. Some examples of these chemicals are:

- **Lead from lead-based paints.**
- **Crystalline silica from bricks, cement and other masonry products.**
- **Arsenic and chromium from chemically-treated lumber.**

Your risk from these exposures varies, depending on how often you do this type of work. To reduce your exposure to these chemicals: Work in a well ventilated area, and work with approved safety equipment, such as those dust masks that are specially designed to filter out microscopic particles.

Table of Contents

- INTRODUCTION..... 3**
 - Foreword 3
 - Contact Info 3
 - Machine Data Sheet..... 4
 - Identification 6
- SECTION 1: SAFETY 7**
 - Safety Instructions for Machinery..... 7
 - Additional Safety Instructions for Planers 9
- SECTION 2: CIRCUIT REQUIREMENTS 10**
 - 220V Single-Phase 10
- SECTION 3: SET UP 11**
 - Set Up Safety 11
 - Items Needed for Set Up 11
 - Unpacking 11
 - Inventory..... 12
 - Clean Up 12
 - Site Considerations 13
 - Moving & Placing Base Unit..... 13
 - Extension Tables..... 14
 - Handwheel 14
 - Dust Port 15
 - Gearbox Oil Level 15
 - Test Run..... 16
 - Tighten V-Belts..... 16
 - Recommended Adjustments 16
- SECTION 4: OPERATIONS 17**
 - Operation Safety 17
 - Basic Operation..... 17
 - Operation Tips..... 18
 - Feed Speed..... 18
 - Bed Rollers..... 19
- SECTION 5: ACCESSORIES 20**
- SECTION 6: MAINTENANCE 22**
 - Schedule 22
 - Cleaning 22
 - V-Belts..... 22
 - Lubrication..... 23

Continued on next page 

SECTION 7: SERVICE	24
About Service	24
Rotating/Changing Carbide Cutters	24
Chain Tension	25
Table Parallelism	25
Rollers & Chip Breaker Heights	27
Spring Tension	29
Chip Deflector Positioning	30
Scale Calibration	30
Anti-Kickback Fingers	31
Pulley Alignment	31
Troubleshooting Guide	32
Electrical Components	34
Wiring Diagram	35
Planer Body Breakdown	36
Table and Base Breakdown	37
Internal Gearbox Breakdown	38
External Gearbox Breakdown	39
Stand and Motor Breakdown	40
Label Placement	41
Parts List	42
Notes	45
WARRANTY AND RETURNS	46



INTRODUCTION

Foreword

We are proud to offer the Model G1021X 15" Extreme Series Planer. This machine is part of a growing Grizzly family of fine woodworking machinery. When used according to the guidelines set forth in this manual, you can expect years of trouble-free, enjoyable operation and proof of Grizzly's commitment to customer satisfaction.

We are pleased to provide this manual with the Model G1021X. It was written to guide you through assembly, review safety considerations, and cover general operating procedures. It represents our effort to produce the best documentation possible.

The specifications, drawings, and photographs illustrated in this manual represent the Model G1021X as supplied when the manual was prepared. However, owing to Grizzly's policy of continuous improvement, changes may be made at any time with no obligation on the part of Grizzly. For your convenience, we always keep current Grizzly manuals available on our website at **www.grizzly.com**. Any updates to your machine will be reflected in these manuals as soon as they are complete. Visit our site often to check for the latest updates to this manual!

Contact Info

If you have any comments regarding this manual, please write to us at the address below:

Grizzly Industrial, Inc.
c/o Technical Documentation Manager
P.O. Box 2069
Bellingham, WA 98227-2069

We stand behind our machines. If you have any service questions or parts requests, please call or write us at the location listed below.

Grizzly Industrial, Inc.
1203 Lycoming Mall Circle
Muncy, PA 17756
Phone: (570) 546-9663
Fax: (800) 438-5901
E-Mail: techsupport@grizzly.com
Web Site: <http://www.grizzly.com>





MACHINE DATA SHEET

Customer Service #: (570) 546-9663 • To Order Call: (800) 523-4777 • Fax #: (800) 438-5901

MODEL G1021X 15" EXTREME SERIES PLANER W/ SPIRAL CUTTERHEAD

Product Dimensions:

Weight530 lbs.
 Length/Width/Height 32 x 48 x 39-3/4 in.
 Foot Print (Length/Width)..... 21-1/2 x 21 in.

Shipping Dimensions:

Type Wood Case
 Content..... Machine
 Weight585 lbs.
 Length/Width/Height..... 27 x 30 x 45-1/4 in.

Electrical:

Switch..... Magnetic with Thermal Overload Protection
 Switch Voltage 220V
 Cord Length 10 ft.
 Cord Gauge 12 gauge
 Recommended Breaker Size 20A
 Included Plug No

Motors:

Main

Type..... TEFC Capacitor Start Induction
 Horsepower..... 3 HP
 Voltage 220V
 Prewired 220V
 Phase Single
 Amps 18A
 Speed 3450 RPM
 Cycle 60 Hz
 Number Of Speeds 1
 Power Transfer Triple Belt Drive
 Bearings Shielded and Lubricated

Main Specifications:

Operation Information

Max. Cut Width 14-7/8 in.
 Max. Cut Height 6-1/8 in.
 Min. Stock Length 6-1/2 in.
 Min. Stock Thickness 1/4 in.
 Max. Stock Thickness 6-1/8 in.
 No. Cuts per Inch 83, 104
 Planing Feed Rate 20, 16 FPM
 Max. Cut Depth Planing Full Width 3/32 in.
 Max. Cut Depth Planing 6 Inch Wide Board..... 1/8 in.



Cutterhead Information

Cutterhead Type Spiral w/Indexable Inserts
Cutterhead Diameter..... 3-1/16 in.
No. of Carbide Inserts..... 72
Carbide Insert Size 14 x 14 x 2mm, 30° Bevels

Table Information

Table Movement 6-1/4 in.
Table Bed Length..... 20-1/2 in.
Table Bed Width 14-7/8 in.
Table Bed Thickness 2 in.
No. of Bed Rollers..... 2
Floor to Table Height 28-1/2 – 34-1/2 in.
Extension Table Length 14 in.
Extension Table Width..... 15-5/8 in.

Construction

Table Precision Ground Cast Iron
Body Cast Iron
Stand..... One Piece Formed Steel
Cutterhead Assembly..... Steel
Infeed Roller..... Spiral Serrated
Outfeed Roller..... Machined
Paint..... Powder Coated

Other

Table Locks..... Two Positive
Measurement Scale Inch and Metric
No. of Dust Ports 1
Dust Port Size 4 in.
Mobile Base G7314

Other Specifications:

ISO Factory ISO 9001
Country Of Origin Taiwan
Warranty..... 1 Year
Serial Number Location Data Label on Upper Cover
Assembly Time 30 minutes

Features:

- Extra Large Ball Bearing Return Rollers
- Large Side Mounted Handwheel
- Cabinet-Style Stand
- Internally Mounted 3HP Motor
- Triple Belt Drive Inside Housing
- Magnetic Switch with Prominent Off Switch
- All Ball Bearing Construction
- 4 Heavy Duty Support Columns
- Anti-Kickback Fingers Prevent Board from Backing Up
- Drive Gears Run in Oil Bath



Identification

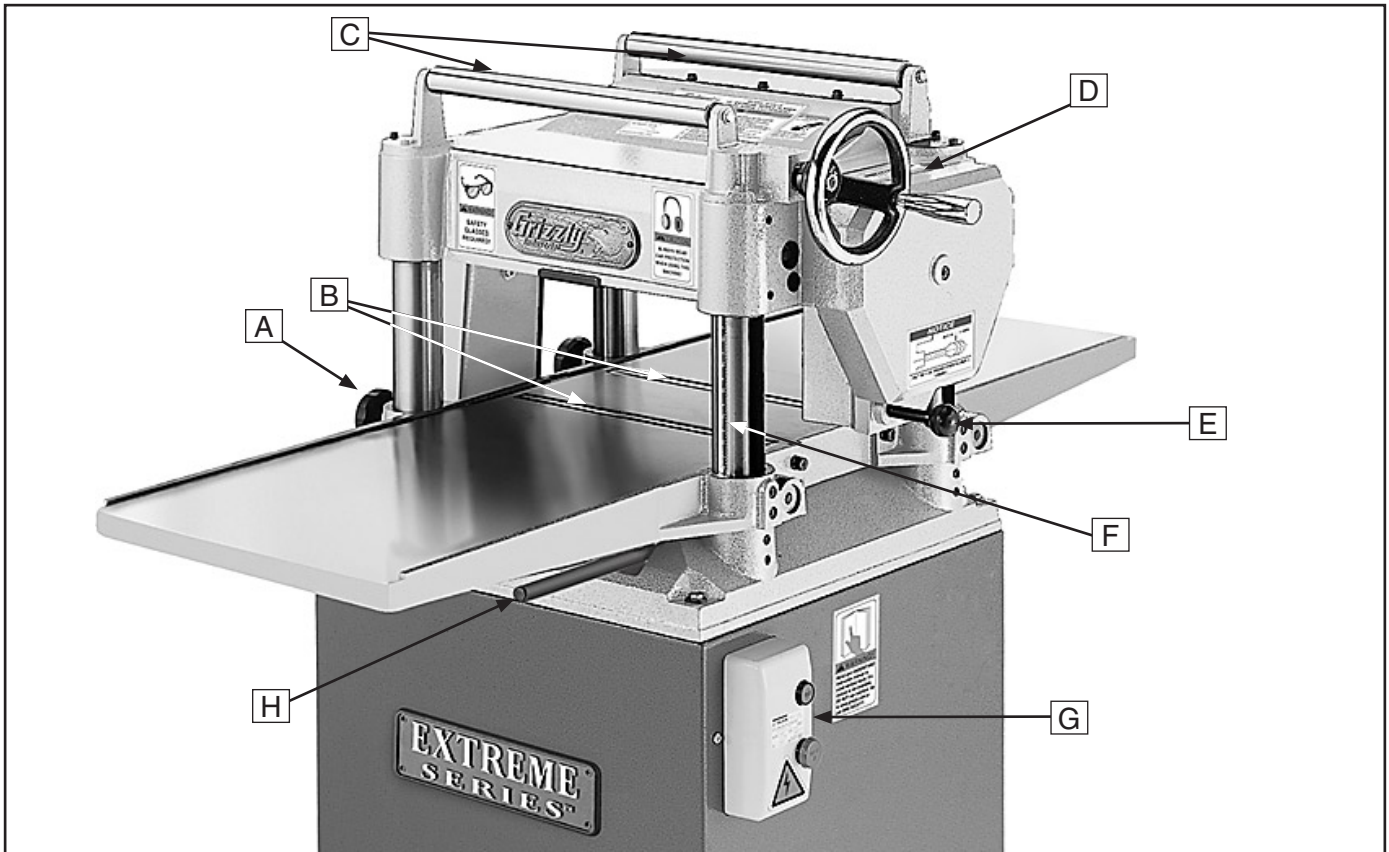

Figure 1. G1021X Identification.

- A. Table Lock Knob
- B. Bed Rollers
- C. Return Rollers
- D. Table Adjustment Handwheel
- E. Feed Rate Control Lever
- F. Table Height Scale
- G. Magnetic Switch
- H. Lifting Bars



SECTION 1: SAFETY

WARNING

For Your Own Safety, Read Instruction Manual Before Operating this Machine

The purpose of safety symbols is to attract your attention to possible hazardous conditions. This manual uses a series of symbols and signal words which are intended to convey the level of importance of the safety messages. The progression of symbols is described below. Remember that safety messages by themselves do not eliminate danger and are not a substitute for proper accident prevention measures.

 **DANGER** Indicates an imminently hazardous situation which, if not avoided, WILL result in death or serious injury.

 **WARNING** Indicates a potentially hazardous situation which, if not avoided, COULD result in death or serious injury.

 **CAUTION** Indicates a potentially hazardous situation which, if not avoided, MAY result in minor or moderate injury. It may also be used to alert against unsafe practices.

NOTICE This symbol is used to alert the user to useful information about proper operation of the machine.

WARNING

Safety Instructions for Machinery

- 1. READ THROUGH THE ENTIRE MANUAL BEFORE STARTING MACHINERY.** Machinery presents serious injury hazards to untrained users.
- 2. ALWAYS USE ANSI APPROVED SAFETY GLASSES WHEN OPERATING MACHINERY.** Everyday eyeglasses only have impact resistant lenses—they are NOT safety glasses.
- 3. ALWAYS WEAR A NIOSH APPROVED RESPIRATOR WHEN OPERATING MACHINERY THAT PRODUCES DUST.** Wood dust is a carcinogen and can cause cancer and severe respiratory illnesses.
- 4. ALWAYS USE HEARING PROTECTION WHEN OPERATING MACHINERY.** Machinery noise can cause permanent hearing damage.
- 5. WEAR PROPER APPAREL. DO NOT** wear loose clothing, gloves, neckties, rings, or jewelry which may get caught in moving parts. Wear protective hair covering to contain long hair and wear non-slip footwear.
- 6. NEVER OPERATE MACHINERY WHEN TIRED, OR UNDER THE INFLUENCE OF DRUGS OR ALCOHOL.** Be mentally alert at all times when running machinery.



WARNING

Safety Instructions for Machinery

7. **ONLY ALLOW TRAINED AND PROPERLY SUPERVISED PERSONNEL TO OPERATE MACHINERY.** Make sure operation instructions are safe and clearly understood.
8. **KEEP CHILDREN AND VISITORS AWAY.** Keep all children and visitors a safe distance from the work area.
9. **MAKE WORKSHOP CHILD PROOF.** Use padlocks, master switches, and remove start switch keys.
10. **NEVER LEAVE WHEN MACHINE IS RUNNING.** Turn power **OFF** and allow all moving parts to come to a complete stop before leaving machine unattended.
11. **DO NOT USE IN DANGEROUS ENVIRONMENTS.** DO NOT use machinery in damp, wet locations, or where any flammable or noxious fumes may exist.
12. **KEEP WORK AREA CLEAN AND WELL LIT.** Clutter and dark shadows may cause accidents.
13. **USE A GROUNDED EXTENSION CORD RATED FOR THE MACHINE AMPERAGE.** Undersized cords overheat and lose power. Replace extension cords if they become damaged. DO NOT use extension cords for 220V machinery.
14. **ALWAYS DISCONNECT FROM POWER SOURCE BEFORE SERVICING MACHINERY.** Make sure switch is in OFF position before reconnecting.
15. **MAINTAIN MACHINERY WITH CARE.** Keep blades sharp and clean for best and safest performance. Follow instructions for lubricating and changing accessories.
16. **MAKE SURE GUARDS ARE IN PLACE AND WORK CORRECTLY BEFORE USING MACHINERY.**
17. **REMOVE ADJUSTING KEYS AND WRENCHES.** Make a habit of checking for keys and adjusting wrenches before turning machinery **ON**.
18. **CHECK FOR DAMAGED PARTS BEFORE USING MACHINERY.** Check for binding and alignment of parts, broken parts, part mounting, loose bolts, and any other conditions that may affect machine operation. Repair or replace damaged parts.
19. **USE RECOMMENDED ACCESSORIES.** Refer to the instruction manual for recommended accessories. The use of improper accessories may cause risk of injury.
20. **DO NOT FORCE MACHINERY.** Work at the speed for which the machine or accessory was designed.
21. **SECURE WORKPIECE.** Use clamps or a vise to hold the workpiece when practical. A secured workpiece protects your hands and frees both hands to operate the machine.
22. **DO NOT OVERREACH.** Keep proper footing and balance at all times.
23. **MANY MACHINES WILL EJECT THE WORKPIECE TOWARD THE OPERATOR.** Know and avoid conditions that cause the workpiece to "kickback."
24. **ALWAYS LOCK MOBILE BASES (IF USED) BEFORE OPERATING MACHINERY.**
25. **BE AWARE THAT CERTAIN DUST MAY BE HAZARDOUS** to the respiratory systems of people and animals, especially fine dust. Make sure you know the hazards associated with the type of dust you will be exposed to and always wear a respirator approved for that type of dust.



WARNING

Additional Safety Instructions for Planers

1. **INSTRUCTION MANUAL.** This machine presents significant safety hazards to untrained users. Read/understand this entire manual before starting the planer.
2. **REACHING INSIDE PLANER.** Never reach inside the planer or remove covers when the planer is connected to power.
3. **INFEED CLEARANCE SAFETY.** The infeed roller is designed to pull material into the cutterhead. Always keep hands, clothing, and long hair away from the infeed roller during operation to prevent serious injury.
4. **BODY POSITION WHILE OPERATING.** The workpiece may kick out during operation. To avoid getting hit, stand to the side of the planer during the entire operation.
5. **PLANING CORRECT MATERIAL.** Only plane natural wood stock with this planer. DO NOT plane MDF, plywood, laminates, or other synthetic products.
6. **GRAIN DIRECTION.** Planing across the grain is hard on the planer and may cause the workpiece to kick out. Always plane in the same direction or at a slight angle with the wood grain.
7. **LOOKING INSIDE PLANER.** Wood chips fly around inside the planer at a high rate of speed. DO NOT look inside the planer or remove guards/covers during operation.
8. **CUTTING LIMITATIONS.** The planer may kick out a workpiece at the operator or be damaged if pushed beyond these limits:
 - Maximum Depth of Cut $\frac{1}{8}$ "
 - Minimum Board Length..... $6\frac{1}{2}$ "
 - Minimum Board Thickness $\frac{1}{4}$ "
 - Maximum # of Boards at One Time.. 1
9. **CLEAN STOCK.** Planing stock with nails, staples, or loose knots MAY cause debris to kick out at the operator and WILL damage your cutters when they contact the cutterhead. Always thoroughly inspect and prepare stock to avoid these hazards.
10. **REMOVING JAMMED WORKPIECES.** To avoid serious injury, always stop the planer and disconnect power before removing jammed workpieces.
11. **DULL/DAMAGED CUTTERS.** The planer may kick out a workpiece at the operator or give poor finish results if it is operated with dull or damaged cutters.
12. **UNPLUGGING DURING ADJUSTMENTS.** When connected to power, the planer can be accidentally turned **ON**. Always disconnect power when servicing or adjusting the components of the planer.
12. **WORKPIECE CLEARANCE.** Always verify workpiece has enough room to exit the planer before starting.

WARNING

Like all machinery there is potential danger when operating this machine. Accidents are frequently caused by lack of familiarity or failure to pay attention. Use this machine with respect and caution to lessen the possibility of operator injury. If normal safety precautions are overlooked or ignored, serious personal injury may occur.

CAUTION

No list of safety guidelines can be complete. Every shop environment is different. Always consider safety first, as it applies to your individual working conditions. Use this and other machinery with caution and respect. Failure to do so could result in serious personal injury, damage to equipment, or poor work results.



SECTION 2: CIRCUIT REQUIREMENTS

220V Single-Phase

!WARNING

Serious personal injury could occur if you connect the machine to the power source before you have completed the set up process. **DO NOT** connect the machine to the power source until instructed to do so.

Amperage Draw

The Model G1021X motor draws the following amps under maximum load:

Motor Draw at 220V 18 Amps

Circuit Requirements

We recommend connecting this machine to a dedicated circuit with a verified ground, using the circuit breaker size given below. Never replace a circuit breaker with one of higher amperage without consulting a qualified electrician to ensure compliance with wiring codes. **If you are unsure about the wiring codes in your area or you plan to connect your machine to a shared circuit, you may create a fire hazard—consult a qualified electrician to reduce this risk.**

220V Circuit Breaker 20 Amps

Plug/Receptacle Type

Recommended Plug/Receptacle.....NEMA 6-20

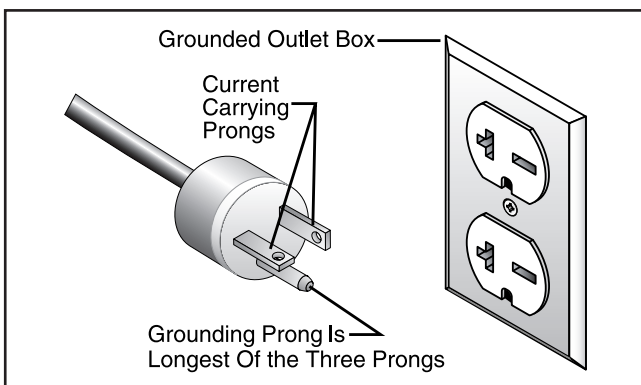
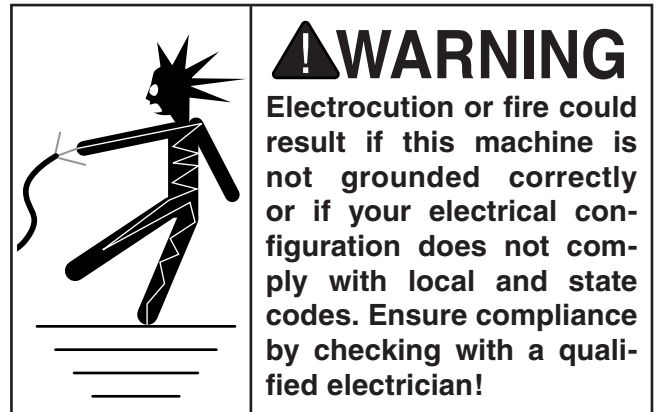

Figure 2. NEMA 6-20 plug and receptacle.

Grounding

In the event of an electrical short, grounding reduces the risk of electric shock. The grounding wire in the power cord must be properly connected to the grounding prong on the plug; likewise, the outlet must be properly installed and grounded. All electrical connections must be made in accordance with local codes and ordinances.



Extension Cords

We do not recommend the use of extension cords. Instead, arrange the placement of your equipment and the installed wiring to eliminate the need for extension cords.

If you find it absolutely necessary to use an extension cord at 220V with your machine:

- Use at least a 12 gauge cord that does not exceed 50 feet in length!
- The extension cord must also contain a ground wire and plug pin.
- A qualified electrician **MUST** size cords over 50 feet long to prevent motor damage.



SECTION 3: SET UP

Set Up Safety

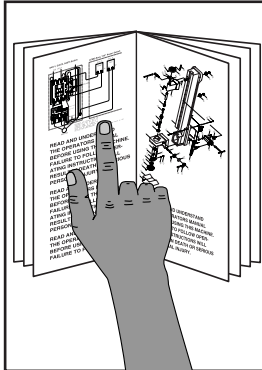

!WARNING
This machine presents serious injury hazards to untrained users. Read through this entire manual to become familiar with the controls and operations before starting the machine!



!WARNING
Wear safety glasses during the entire set up process!

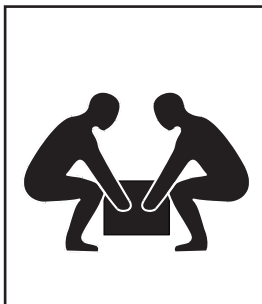

!WARNING
The Model G1021X is a heavy machine. DO NOT over-exert yourself while unpacking or moving your machine—get assistance.

Items Needed for Set Up

The following items are needed to complete the set up process, but are not included with your machine:

Description	Qty
• Straightedge 4' (or longer)	1
• Safety Glasses (for each person)	1
• Dust Collection System	1
• 4" Dust Hose (length as needed)	1
• 4" Hose Clamp	1
• Rotacator (see Page 20)	1
• Phillips Screwdriver	1
• Flat Head Screwdriver	1
• Forklift	1
• Shop Rags	As needed
• Degreaser	As needed

Unpacking

The Model G1021X was carefully packed when it left our warehouse. If you discover the machine is damaged after you have signed for delivery, *please immediately call Customer Service at (570) 546-9663 for advice.*

Save the containers and all packing materials for possible inspection by the carrier or its agent. *Otherwise, filing a freight claim can be difficult.*

When you are completely satisfied with the condition of your shipment, you should inventory the contents.



Inventory

After all the parts have been removed from the two boxes, you should have the following items:

Box 1: (Figure 3)	Qty
A. Planer Unit (not shown).....	1
B. Extension Tables.....	2
C. Dust Port.....	1
D. Handwheel.....	1

Tools and Hardware:

Cap Screws M6-1 x 12 (Dust Port).....	3
Hex Bolts M6-1 x 12 (Dust Port).....	3
Hex Nuts M6-1 (Dust Port).....	3
Lock Washers 6mm (Dust Port).....	3
Flat Washers 6mm (Dust Port).....	3
Hex Bolts M8-1.25 x 25 (Ext. Tables).....	6
Set Screws M8-1.25 x 20 (Ext. Tables).....	6
Hex Nut M10-1.25 (Handwheel).....	1
Flat Washer 10mm (Handwheel).....	1
Scale (Hi-Lo) (Handwheel).....	1
Key 4 x 4 x 10 (Handwheel).....	1
Handwheel Handle (Handwheel).....	1
Torx T-Handle Wrench 1/2".....	1
Flat Head Torx Screws M6-1 x 15.....	10
Torx Bits T-20.....	5
Indexable Carbide Inserts.....	5
Hex Wrenches 3, 4, 5, 6mm.....	1 ea.
Wrenches 8/10, 12/14mm.....	1 ea.

In the event that any nonproprietary parts are missing, we would be glad to replace them, or for the sake of expediency, replacements can be obtained at your local hardware store.

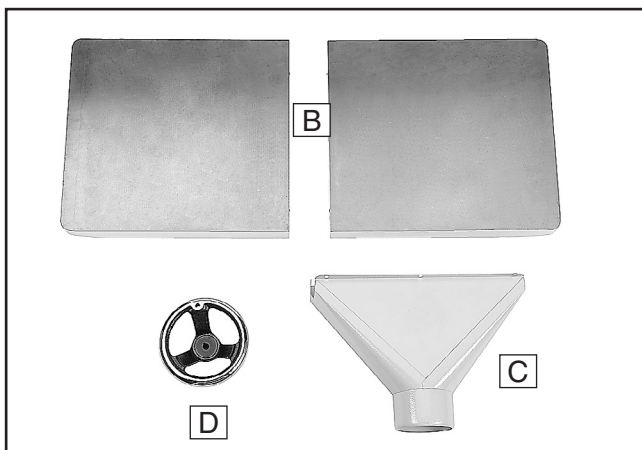



Figure 3. G1021X Component Inventory.

NOTICE

Some hardware/fasteners on the inventory list may arrive pre-installed on the machine. Check these locations before assuming that any items from the inventory list are missing.

Clean Up

The unpainted surfaces are coated with a waxy oil to protect them from corrosion during shipment. Remove this protective coating with a solvent cleaner or citrus-based degreaser such as Grizzly's G7895 Degreaser. To clean thoroughly, some parts may need to be removed. **For optimum performance from your machine, make sure you clean all moving parts or sliding contact surfaces that are coated.** Avoid chlorine-based solvents, such as acetone or brake parts cleaner, as they may damage painted surfaces should they come in contact. Always follow the manufacturer's instructions when using any type of cleaning product.



! WARNING
Gasoline and petroleum products have low flash points and could cause an explosion or fire if used to clean machinery. **DO NOT** use gasoline or petroleum products to clean the machinery.

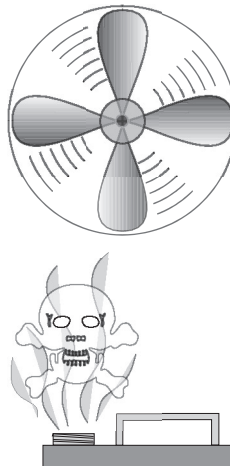

! CAUTION
Many of the solvents commonly used to clean machinery can be toxic when inhaled or ingested. Lack of ventilation while using these solvents could cause serious personal health risks or fire. Take precautions from this hazard by only using cleaning solvents in a well ventilated area.



Site Considerations

Floor Load

Refer to the **Machine Data Sheet** for the weight and footprint specifications of your machine. Some floors may require additional reinforcement to support both the machine and operator.

Working Clearances

Consider existing and anticipated needs, size of material to be processed through each machine, and space for auxiliary stands, work tables or other machinery when establishing a location for your new machine. See **Figure 4** for the minimum working clearances.

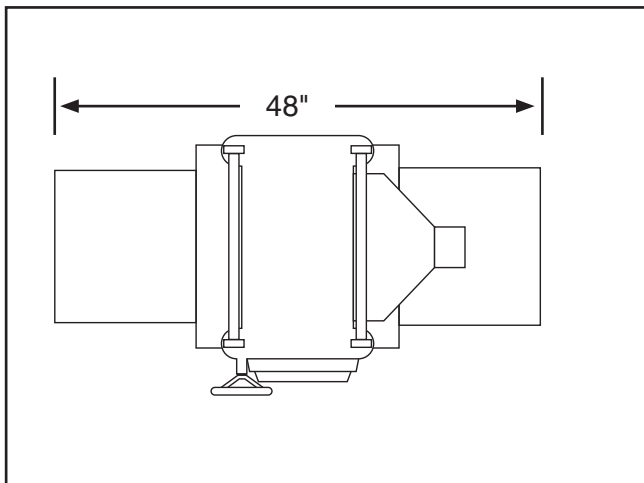
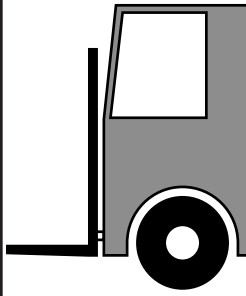

Figure 4. Minimum working clearances.

	<p>⚠ CAUTION</p> <p>Unsupervised children and visitors inside your shop could cause serious personal injury to themselves. Lock all entrances to the shop when you are away and DO NOT allow unsupervised children or visitors in your shop at any time!</p>
---	--

Moving & Placing Base Unit

	<p>⚠ WARNING</p> <p>This planer is a heavy machine with a shipping weight of 585 lbs. Serious personal injury may occur if safe moving methods are not followed. To be safe, you will need assistance and power equipment when moving the shipping crate and removing the machine from the crate.</p>
--	--

The cabinet stand on the Model G1021X is equipped with lifting bars (see **Page 6**) to lift and place the planer.

When lifting the planer with a forklift, place shop rags or cardboard between the forks and cabinet base so you do not scratch the paint.

Figure 5 shows an example of a planer being lifted using a forklift.

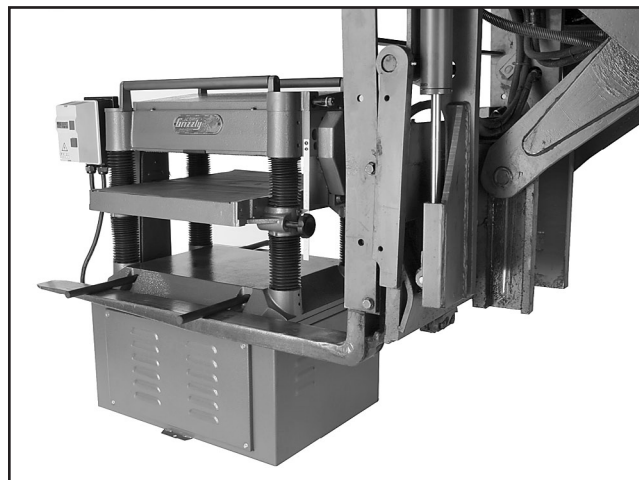

Figure 5. Example of lifting planer with forklift.



Extension Tables

Components and Hardware Needed:	Qty
Extension Tables	2
Hex Bolts M8-1.5 x 25.....	6
Set Screws M8-1.25 x 20	6

To attach the extension tables:

1. Attach the extension tables to the planer table with the hex bolts, as shown in **Figure 6**, but do not fully tighten the bolts at this time.
2. Insert the set screws into the locations shown in **Figure 6**.

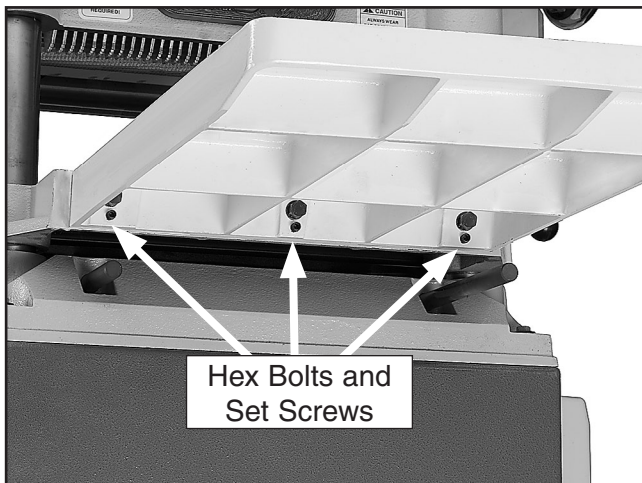

Figure 6. Extension table attached to bed.

3. Using the straightedge as a guide, turn the set screws individually until the extension tables are level with the table, and then fully tighten the hex bolts.

Handwheel

Components and Hardware Needed:	Qty
Handwheel	1
Handwheel Handle	1
Key 4 x 4 x 10.....	1
Hi-Lo Scale.....	1
Hex Nut M10-1.25.....	1
Flat Washer 10mm	1

To install the handwheel:

1. Fit the handwheel key into the keyway on the handwheel shaft.
2. Slide the handwheel onto the handwheel shaft, ensuring the key fits into the keyway inside the handwheel bore.
3. Slide the Hi-Lo scale onto the handwheel shaft, and secure the handwheel using the included 10mm flat washer and M10-1.25 hex nut.
4. Thread the handwheel handle into the hole in the handwheel, and tighten the jam nut.



Figure 7. Handwheel installed on shaft (handwheel handle removed for clarity).



Dust Port

⚠ CAUTION

DO NOT attach the dust port if you do not intend to connect your planer to a dust collection system. Accumulated wood chips could cause a malfunction, resulting in personal injury or damage to the planer.

Components and Hardware Needed:	Qty
Dust Port	1
Hex Bolts M6-1 x 12.....	3
Cap Screws M6-1 x 12.....	3
Flat Washers 6mm	3
Lock Washers 6mm.....	3
Hex Nuts M6-1	3

To install the dust hood:

1. Secure the dust port to the planer upper cover with the hex bolts, hex nuts, and flat washers, as shown in **Figure 8**. It will be necessary to reach inside the port opening with a wrench to hold the nut while tightening the hex bolts.

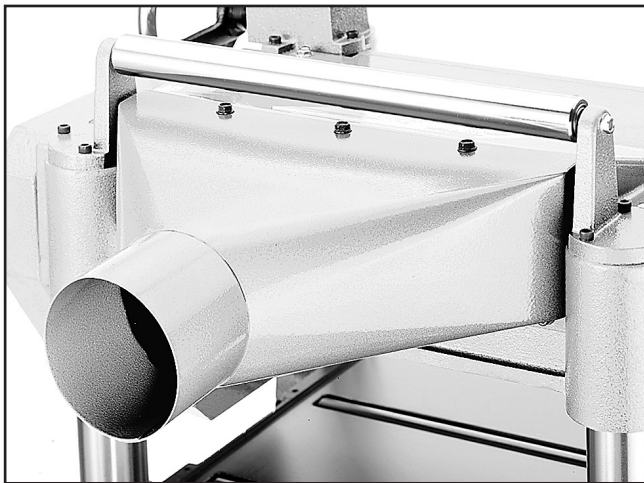

Figure 8. Dust port attached.

2. Use the cap screws and lock washers to secure the dust port to the planer head casting.

Gearbox Oil Level

Before starting your machine for the first time, make sure the gearbox has oil.

To check the gearbox oil level:

1. Using a 14mm wrench, remove the gearbox fill plug (**Figure 9**).

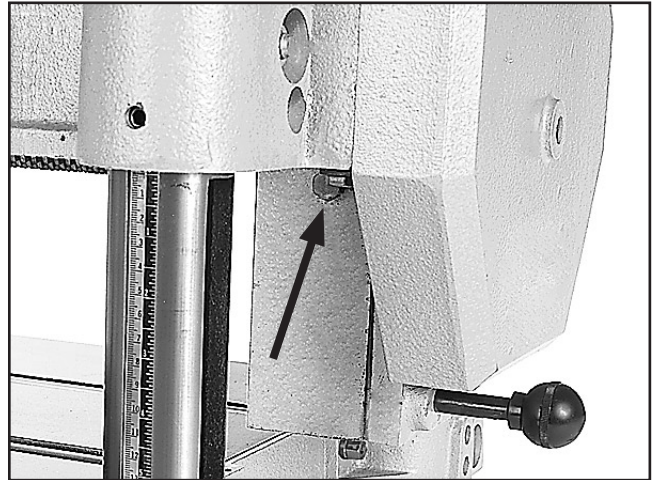
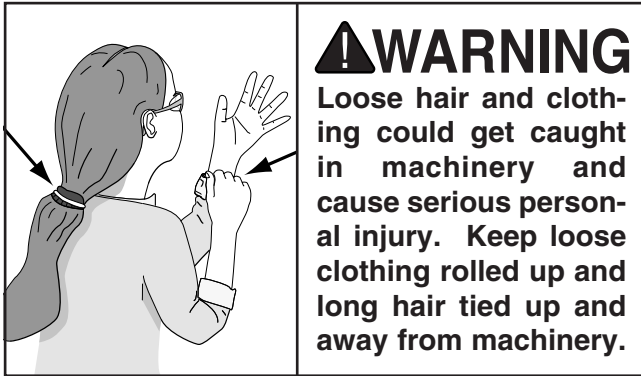

Figure 9. Gearbox fill plug location.

2. Using the short end of the 6mm hex wrench, dip it inside the fill hole and remove it.
 - If the end of the hex wrench is coated with oil, then the gearbox oil level is okay. Replace the fill plug and skip to the next section.
 - If the end of the hex wrench is not coated with oil, then you need to add more oil. Refer to **Page 23** for instructions on how to do this.



Test Run



To perform a test run:

1. Read the entire instruction manual, and make sure oil is in the gearbox.
2. Make sure all tools and foreign objects have been removed from the machine.
3. Put on safety glasses, and secure loose clothes or long hair.
4. Connect the planer to the power source.
5. Press the green button to turn the machine **ON**. The planer should run smoothly with little or no vibration.
 - If you suspect any problems, immediately stop the planer by pushing the red **OFF** button. Troubleshoot and fix any problems before starting the planer again.
 - If you need any help with your planer call our Tech Support at (570) 546-9663.

Tighten V-Belts

The final step in the set up process must be done after approximately 16 hours of operation. During this first 16 hours, the V-belts will stretch and seat into the pulley grooves. After this time, the V-belts must be retensioned or belt failure will occur quickly. Refer to **Page 22** when you are ready to perform this important adjustment.

Note: Pulleys and belts run very hot. This is a normal condition. Allow them to cool before making adjustments. A collection of black belt dust at the bottom of the belt housing is a normal during the life of the machine.

Recommended Adjustments

For your convenience, the adjustments listed below have been performed at the factory and no further setup is required to operate your machine.

However, because of the many variables involved with shipping, some of these adjustments may need to be repeated to ensure optimum cutting results. Keep this in mind as you start to use your new planer.

Step-by-step instructions for these adjustments can be found in SECTION 7: SERVICE ADJUSTMENTS.

1. Table Parallelism (**Page 25**).
2. Chain Drive Tension (**Page 25**).
3. Infeed/Outfeed Roller Height (**Page 27**).
4. Spring Tension (**Page 29**).
5. Chip Breaker Height (**Page 27**).
6. Chip Deflector Positioning (**Page 30**).



SECTION 4: OPERATIONS

Operation Safety

!WARNING

Damage to your eyes, lungs, and ears could result from using this machine without proper protective gear. Always wear safety glasses, a respirator, and hearing protection when operating this machine.

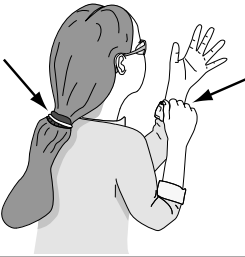
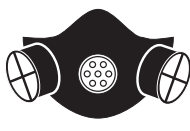

!WARNING

Loose hair and clothing could get caught in machinery and cause serious personal injury. Keep loose clothing and long hair away from moving machinery.

NOTICE

If you have never used this type of machine or equipment before, WE STRONGLY RECOMMEND that you read books, trade magazines, or get formal training before beginning any projects. Regardless of the content in this section, Grizzly Industrial will not be held liable for accidents caused by lack of training.

Basic Operation

The basic steps of operating the planer are as follows:

1. Put on safety glasses.
2. Unless your workpiece starts very flat, surface plane the workpiece on a jointer until it is flat.
3. Adjust table height to slightly lower than your workpiece height to ensure the first cut is as light as possible.
4. Start the planer.
5. Place the flat side of the board down on the table, and feed the workpiece through the planer, making sure not to stand directly in front or behind the workpiece.

—If the cut is too heavy and bogs down the planer, turn the planer **OFF** immediately, allow it to come to a complete stop, remove the workpiece, and repeat **Steps 3–5**.
6. Measure your workpiece thickness and adjust the table height as necessary to take a lighter or heavier pass, depending on your needs.



Operation Tips

- Inspect lumber for defects, warping, cupping, twisting, and for foreign objects (nails, staples, imbedded gravel, etc.). If you have any question about the quality of your lumber, do not use it. Remember, wood stacked on a concrete floor can have small pieces of stone or concrete pressed into the surface.
- Use the full width of the planer. Alternate between the left, the right, and the middle when feeding lumber into the planer. Your cutters will remain sharp much longer.
- Scrape all glue off joined boards before planing.
- Plane ONLY natural wood fiber. DO NOT plane MDF, plywood, laminates, or other synthetic products.
- Plane wood with the grain. Never feed end-cut or end-grained lumber into your planer.
- Do not use boards with loose or large knots, splits, crossgrain or other obvious blemishes or defects. They can damage the machine and pose the possibility of operator injury.
- Keep your work area clear.
- When making multiple passes on long stock, use the stock return rollers on the top of the machine to move the material back to the infeed side of the machine.
- Avoid planing wood with a high water content. Wood with more than 20% moisture content or wood exposed to excessive moisture (such as rain or snow), will plane poorly and cause excessive wear to the cutters and motor. Excess moisture can also hasten rust and corrosion of the planer and/or individual components.

Feed Speed

The infeed and outfeed rollers power the stock through the planer while keeping boards flat and providing a consistent rate of movement.

The power feed features 16 FPM and 20 FPM feed rates. The speed should be changed ONLY when the machine is running.

Figure 10 illustrates the three different positions of the feed control knob. Moving the knob toward the machine (Position A) produces the 20 FPM feed speed; moving away from the machine (Position C) produces 16 FPM; and moving the knob to the center position (Position B) places the gearbox in neutral.

NOTICE

Change the speeds when the planer is running, but DO NOT attempt to change speeds during any cutting operations or damage to the gearbox will result.

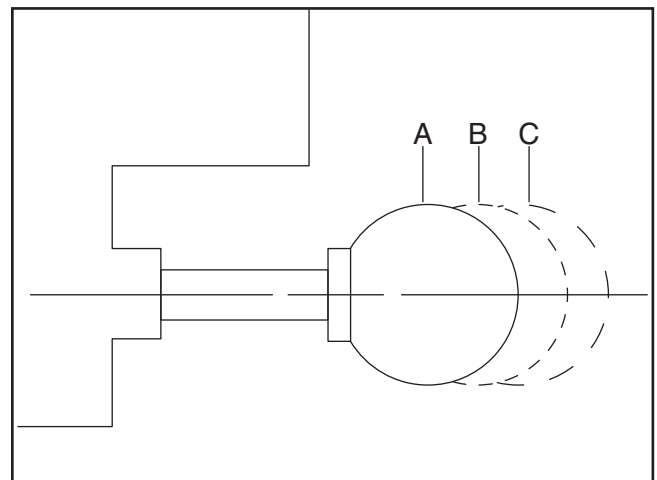

Figure 10. Feed control knob positions.



Bed Rollers

Adjustment Height Range0.002"–0.020"

Tools Needed:	Qty
Hex Wrench 3mm.....	1
Open End Wrench 12mm.....	1
Rotacator (optional, Page 20).....	1

The height of the bed rollers will vary, depending on the type of material you intend to plane, but as a general rule keep the roller height within 0.002"–0.020" above the table. When planing rough stock, set the rollers high to keep the lumber from dragging along the bed. When planing milled lumber, set the rollers low to help minimize snipe.

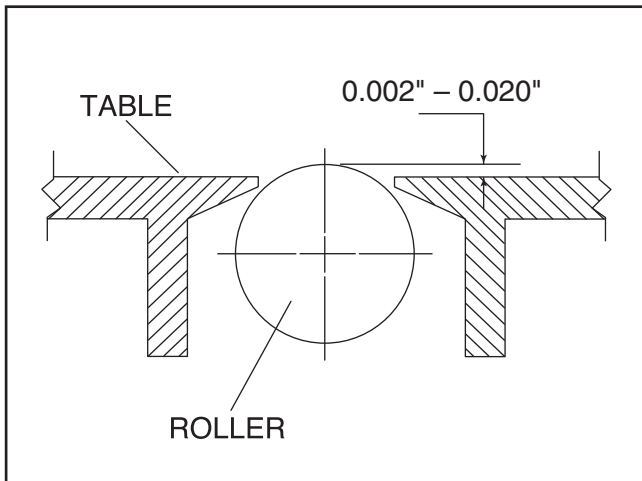

Figure 11. Bed roller height range.

To ensure accurate results and make the adjustment process quicker and easier, we recommend using a Rotacator (see **Page 20**) to gauge the bed roller height from the table. If a Rotacator is not available, a straightedge and feeler gauges can be used, but care must be taken to achieve satisfactory results.

Note: *Misaligned bed rollers can be the root of many planing problems, such as:*

- *Workpiece chatter and/or noisy operation*
- *Washboard surfaces*
- *Workpiece rotating during planing*
- *Tapered cuts*
- *Binding, causing the workpiece to jam*

To adjust the bed rollers:

1. Lower the table to give yourself at least 4" of working room below the cutterhead.
2. Loosen the locking set screws (**Figure 12**) above the roller adjusters (4 total).

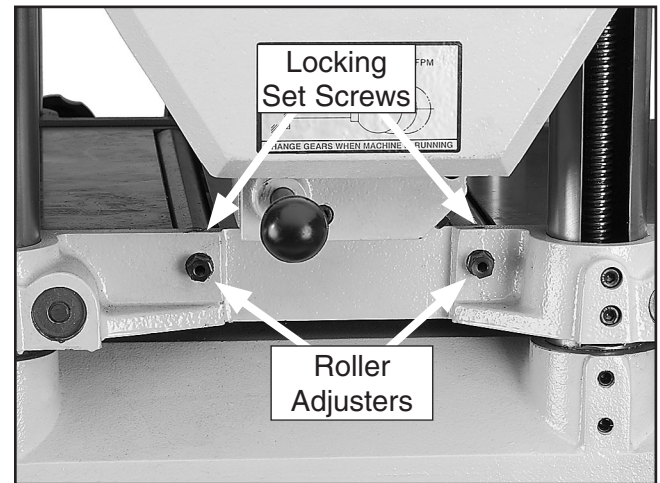

Figure 12. Bed roller controls (only one side shown).

3. Raise or lower the rollers by rotating the adjusters to reach your desired height.
4. Verify both sides of the bed roller are at the same height and lock them in position with the locking set screws.
5. Double check the roller heights to make sure they did not move when you locked them (if they did, repeat the procedure).



SECTION 5: ACCESSORIES

G1738—Rotacator™ Precision Planer Tool

The Rotacator is a dial indicator on a magnetic base and is designed for quickly and accurately setting the critical tolerances needed when adjusting any planer, so that nasty surprises such as non-parallel and chattered cuts can be eliminated. Helps adjust infeed/outfeed rollers, pressure bars, chip breakers, and bed rollers. Also a great setup tool for other machines! Accurate to 0.001". Indicator rotates 360°.



Figure 13. Rotacator™ Precision Planer Tool.

H7319—10 Pack of Indexable Carbide Inserts

Replacement carbide inserts for G1021X.

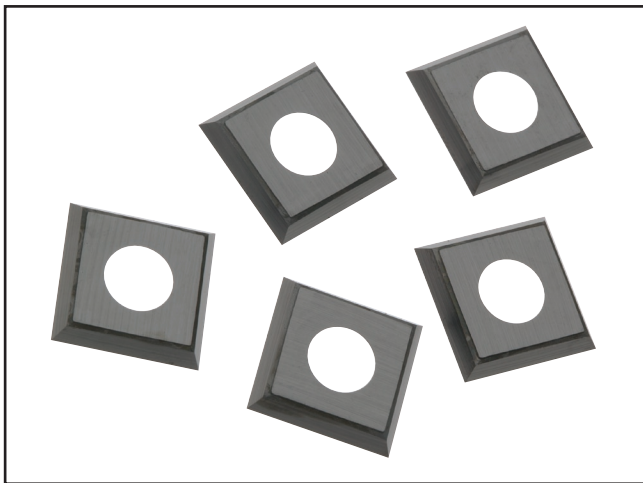

Figure 14. H7319 Indexable Carbide Inserts.

G7314—Heavy-Duty SHOP FOX® Mobile Base

Make your machine mobile with this popular patented mobile base. The unique outrigger type supports increase stability and lower machine height. This super heavy duty mobile base is rated for up to a 700 lb. capacity.



Figure 15. G7314 SHOP FOX® Mobile Base.

G3639—Power Twist® V-Belt - 3/8" x 48"

Smooth running with less vibration and noise than solid belts. The Power Twist® V-belts can be customized in minutes to any size—just add or remove sections to fit your needs. Requires four Power Twist® V-belts to replace the stock V-belts on your Model G1021X.

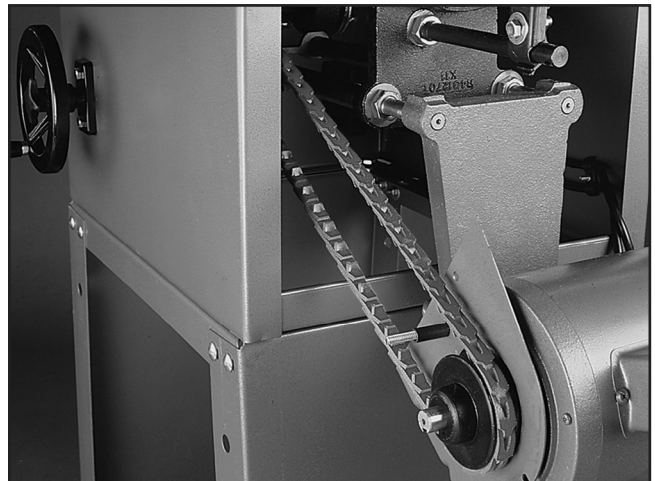

Figure 16. G8127 Power Twist® V-Belt.



- G9256—6" Dial Caliper**
- G9257—8" Dial Caliper**
- G9258—12" Dial Caliper**

Essential for planing, jointing, or sanding to critical tolerances. These traditional dial calipers are accurate to 0.001" and can measure outside surfaces, inside surfaces, and heights/depths. Features stainless steel, shock resistant construction and a dust proof display. An absolute treat for the perfectionist!

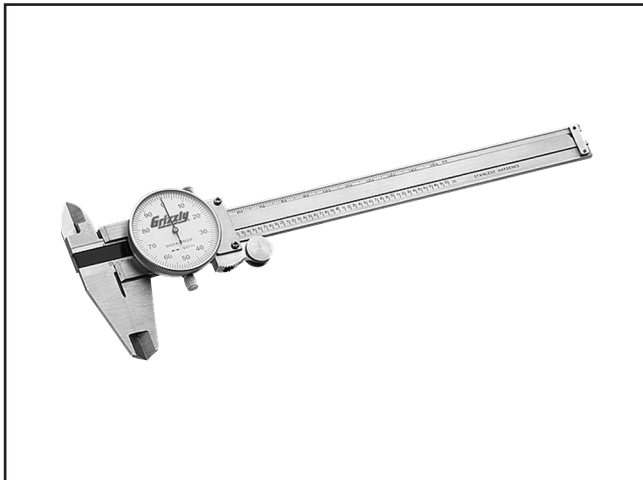

Figure 17. Grizzly® Dial Calipers.

- H1302—Standard Earmuffs**
 - H4979—Deluxe Twin Cup Hearing Protector**
 - H4977—Work-Tunes Radio Headset Earmuffs**
- Protect yourself comfortably with a pair of cushioned earmuffs. Especially important if you or employees operate for hours at a time.



Figure 18. Our most popular earmuffs.

Call 1-800-523-4777 To Order

- G5562—SLIPIT® 1 Qt. Gel**
- G5563—SLIPIT® 12 oz Spray**
- G2871—Boeshield® T-9 12 oz Spray**
- G2870—Boeshield® T-9 4 oz Spray**
- H3788—G96® Gun Treatment 12 oz Spray**
- H3789—G96® Gun Treatment 4.5 oz Spray**



Figure 19. Recommended products for protecting unpainted cast iron/steel parts on machinery.



SECTION 6: MAINTENANCE

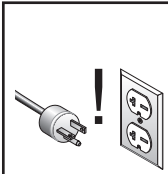

! WARNING

Always disconnect power to the machine before performing maintenance. Failure to do this may result in serious personal injury.

Schedule

For optimum performance from your machine, follow this maintenance schedule and refer to any specific instructions given in this section. Refer to **Lubrication** on **Page 23** for specific lubrication instructions.

Daily:

- Clean unpainted cast iron part of table
- Lubricate feed rollers

Weekly Maintenance:

- Clean cutterhead
- Lubricate four columns

Monthly Check:

- Inspect V-belt tension, damage, or wear
- Clean/vacuum dust buildup from inside cabinet and off motor
- Lubricate worm gear
- Lubricate chain
- Lubricate drive chain

Yearly:

- Change gear box oil (should be performed after the first 20 hrs when planer is new)

Cleaning

Vacuum excess wood chips and sawdust, and wipe off the remaining dust with a dry cloth—this ensures moisture from wood dust does not remain on bare metal surfaces. Treat all unpainted cast iron and steel with a non-staining lubricant after cleaning. We recommend products like SLIPIT®, G96® Gun Treatment, or Boeshield® T-9 (see **Page 21** for more details).

V-Belts

Adjust/replace belts by using the hex nuts on the motor mount bolt (**Figure 20**) to control the tension. The correct tension for the V-belts is $\frac{1}{4}$ " deflection when pushed in the center with moderate pressure. After the first 16 hours of belt life, retension them, as they will stretch and seat during this time.

Always replace the V-belts with a matched set of 3 belts, or belt tension may not be even among the 3 belts and can cause premature belt failure.



Figure 20. Motor mount bolt.



Lubrication

The Model G1021X features factory-sealed bearings. Should a bearing fail, your planer will probably develop a noticeable rumble/vibration, which will increase when the machine is put under load. Bearings are standard sizes and can be replaced through Grizzly.

Proper lubrication of other planer components are essential for long life and trouble-free operation. Below is a list of components that require periodic lubrication. Schedules are based on daily use. Adjust accordingly for your level of use.

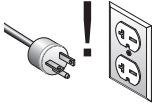
	<p>⚠ WARNING</p> <p>Always disconnect power to the machine before lubricating! Failure to do this may result in serious personal injury.</p>
---	--

Columns/Lead Screws: The four columns should be lubricated weekly with SAE 30W oil. Unfasten dust covers to gain access. The four lead screws should be lubricated with general purpose grease once a month.

Worm Gear: The worm gear should be inspected monthly and lubricated with general purpose grease when needed. Remove the worm gear box to inspect. See parts diagram for location.

Chain: The table height adjustment chain should be inspected monthly and lubricated with general purpose grease when needed.

Gear Box: Gear box oil should be changed after the first 20 hours of operation (see **Figure 21**). It is not necessary to remove the chain drive cover to access the fill/drain plugs, but doing so will give you easier access.

Replace with 80W-90W gear oil. Inspect levels periodically and change yearly. Replace gear oil more frequently under heavy use. Fill until oil reaches the top of the filler plug port for correct oil level.

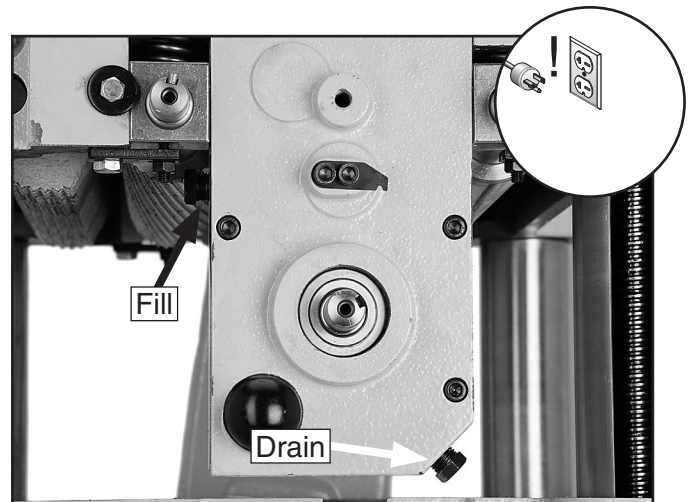

Figure 21. Gearbox oil drain/fill locations (sprockets and chains removed for clarity).

Drive Chain: The drive chain should be inspected and lubricated monthly. Check sprockets, chains and cotter pins during inspection. Some chains will have master links instead of cotter pins.

Feed Rollers: Daily lubrication of feed rollers is crucial to the operation of your planer. Lubricate before start-up. Each end of each power feed roller has an oiling port located on the top of the head casting (**Figure 22**). Apply a SAE 30W oil, making sure that the lubricant penetrates the bearing.



Figure 22. Tension screw locations.

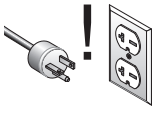

SECTION 7: SERVICE

	<p>⚠ WARNING Always disconnect power to the machine before performing service adjustments. Failure to do this may result in serious personal injury.</p>
---	---

About Service

This section is designed to help the operator with adjustments that were made at the factory and that might also need to be made during the life of the machine.

This section is provided for your convenience—it is not a substitute for the Grizzly Service Department. If any adjustments arise that are not described in this manual, then feel free to call Tech Support at (570) 546-9663.

Similarly, if you are unsure of how to perform any procedure in this section, Tech Support will be happy to guide you through the procedures or help in any other way.

Rotating/Changing Carbide Cutters

Tools Needed: Qty
T-Handle Wrench w/T20 Torx Bit..... 1

The cutterhead is equipped with 72 indexable carbide cutters. Each cutter can be rotated to reveal any one of its four cutting edges. Therefore, if one cutting edge becomes dull or damaged, simply rotate it 90° to reveal a fresh cutting edge, as shown in **Figure 23**.

In addition, each cutter has a reference dot on one corner. As the cutter is rotated, the reference dot location can be used as an indicator of which edges are used and which are new. When the reference dot revolves back around to its starting position, the cutter should be replaced.

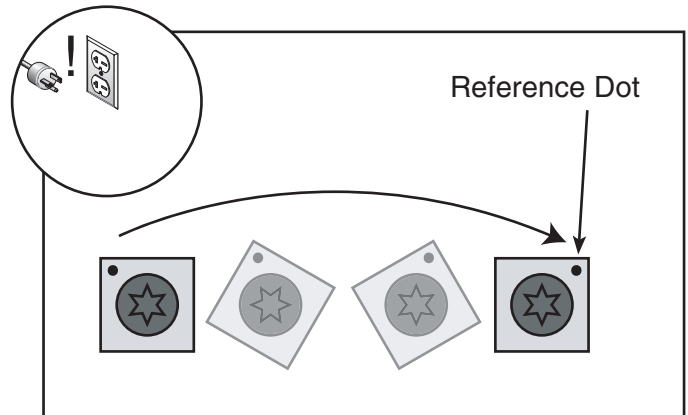

Figure 23. Cutter rotating sequence.

To rotate or change a carbide cutter:

1. DISCONNECT THE PLANER FROM THE POWER SOURCE!
2. Remove any sawdust from the head of the carbide cutter Torx screw.
3. Remove the Torx screw and carbide cutter.
4. Clean all dust and dirt off the cutter and the cutterhead pocket from which the cutter was removed, and replace the cutter so a fresh, sharp edge is facing outward.
5. Lubricate the Torx screw threads with a light machine oil, wipe the excess oil off the threads, and torque the Torx screw to 48-50 inch/pounds.

Note: Proper cleaning is critical to achieving a smooth finish. Dirt or dust trapped between the cutter and cutterhead will slightly raise the cutter, and make a noticeable marks on your workpieces the next time you plane.

Note: Excess oil may squeeze between the cutter and cutterhead, thereby lifting the cutter slightly and affecting workpiece finishes.



Chain Tension

Tools Needed:	Qty
Phillips Screwdriver #2.....	1
Wrench or Socket 12mm.....	1

The chain drive transfers movement from the handwheel to elevate the table. The chain drive can be adjusted to remove slack if the chain stretches over time or during table leveling procedures.

To adjust the chain tension:

1. DISCONNECT THE PLANER FROM THE POWER SOURCE!
2. Remove the motor access panel.
3. Loosen the two locking bolts and move the idler sprocket until chain play has been eliminated (**Figure 24**).

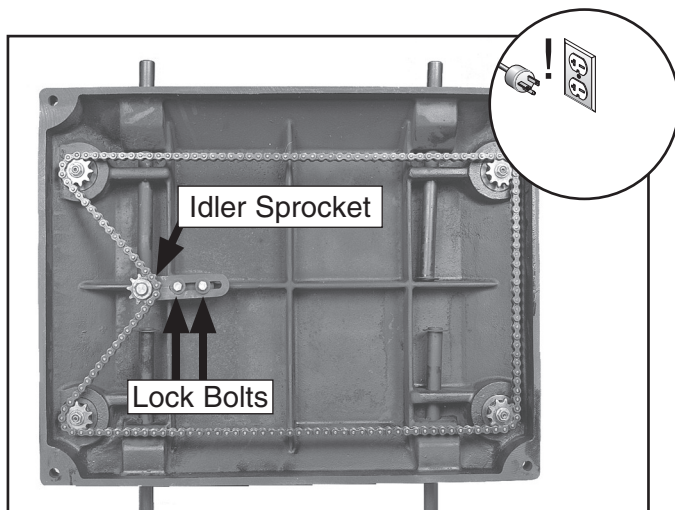

Figure 24. Underside of table.

4. Re-tighten the two locking bolts.
5. Check chain lubrication. Refer to **SECTION 6: MAINTENANCE** on **Page 22** for further details.

NOTICE

DO NOT let the chain fall off the sprockets—returning it to its proper location without changing the table adjustments can be very difficult.

Table Parallelism

Maximum Allowable Tolerances:	
Cutterhead/Table Side-to-Side.....	0.002"
Head Casting/Table Front/Back.....	0.020"

Table parallelism is critical to the operation of the machine. As such, it is essential that the table is parallel with the cutterhead (within 0.002") from side-to-side, as illustrated in **Figure 25**.

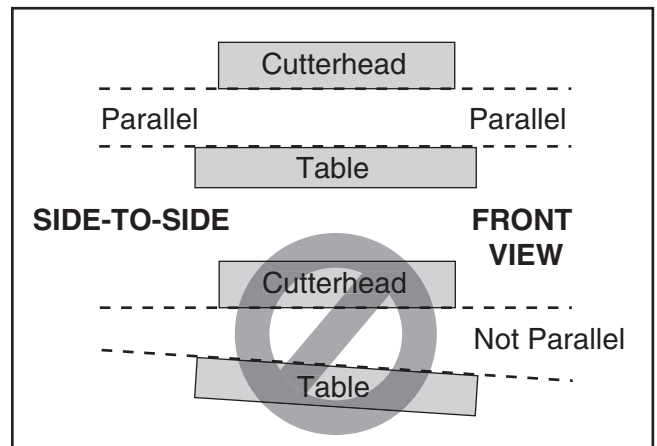

Figure 25. Side-to-side parallelism of table and cutterhead.

How the table sits in relation to the head casting from front-to-back is also important (see **Figure 26**). Because the feed rollers, pressure bar, and chip breaker will be adjusted off the table position, the tolerances on the front-to-back positioning are not as critical as the cutterhead/table side-to-side positioning. Therefore, the maximum allowable tolerance for the front-to-back parallelism is not more than 0.020".

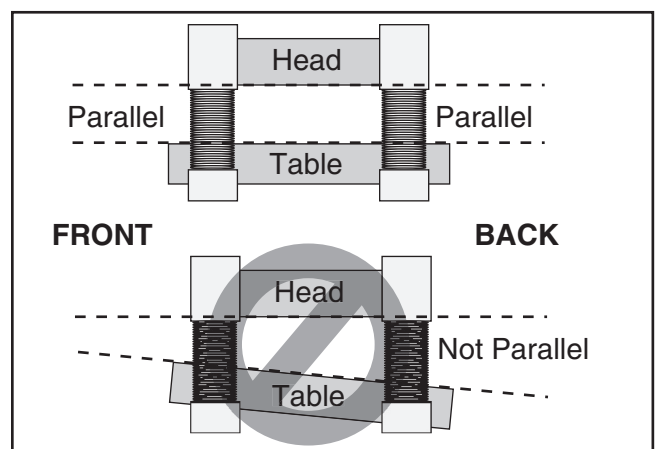

Figure 26. Front-to-back parallelism.



Table Parallelism Inspection

Use your Rotacator to inspect the table parallelism. If you do not have a Rotacator, a wood block and feeler gauges may be used, but extra care must be taken to ensure accuracy. If the table is not within the maximum allowable tolerances, it must be adjusted.

Table Parallelism Adjustments

The table is adjusted by turning the chain sprockets underneath the table for movements over 0.016" or by adjusting how the table is mounted on the columns for movements under 0.016".

NOTICE

When making adjustments, tighten fasteners after each step to ensure the accuracy of your tests. When adjusting the chain sprockets, keep in mind that if the chain becomes too loose, it will fall off of all the sprockets. Returning it to its proper location can be frustrating.

To adjust the table parallelism:

1. DISCONNECT THE PLANER FROM THE POWER SOURCE!
2. Remove the cabinet panel and locate the chain on the underside of the table.
3. Loosen the idler sprocket (see **Chain Tension** instructions on **Page 25**).
4. Move the chain away from only the sprocket you want to adjust so only that sprocket can be turned independent of the chain.

Note: If the left side of the table is too high, the left two sprockets will need to be adjusted. Each tooth on the sprocket represents .016" of vertical movement as the cogs are turned. Make sure, as you turn the sprockets, to keep an accurate tooth count to ensure that the table is adjusted equally.

5. Mark the location of one tooth in the sprocket that you are adjusting.

6. Carefully turn the sprocket (clockwise to lower the table; counterclockwise to raise the table) just enough to position the next tooth at the marked location, then fit the chain around sprocket again.
7. Repeat **Steps 4–6** with each sprocket that needs to be adjusted until the table-to-cutterhead clearance is within 0.016" from one side to the other.
8. Make sure the chain is properly fitted on the sprockets and tighten the idler sprocket and lock bolts.
9. Micro-adjust the table position by loosening the cap screws shown in **Figure 27** and lifting the table upward or downward until the table and cutterhead are in alignment.

Note: This process may require adjusting the columns on both the left and right hand sides until you find the correct combination.

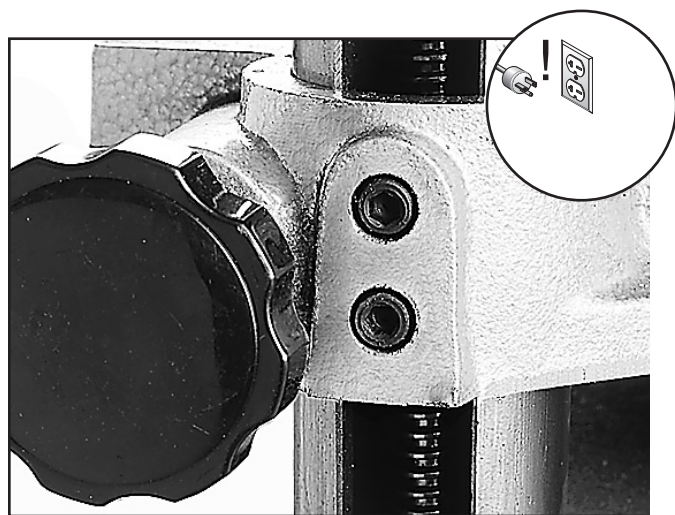

Figure 27. Close up of table micro-adjustment screws (one side shown only).



Rollers & Chip Breaker Heights

Distance Below Cutter Edge at BDC*

Infeed Roller	0.040"
Chip Breaker	0.040"
Outfeed Roller	0.040"

Tools Needed:

	Qty
Hex Wrench 3mm.....	1
Hex Wrench 5mm.....	1
Wrench or Socket 10mm.....	1
Rotacator (optional, Page 20).....	1

*BDC = Bottom Dead Center (see **Figure 28**).

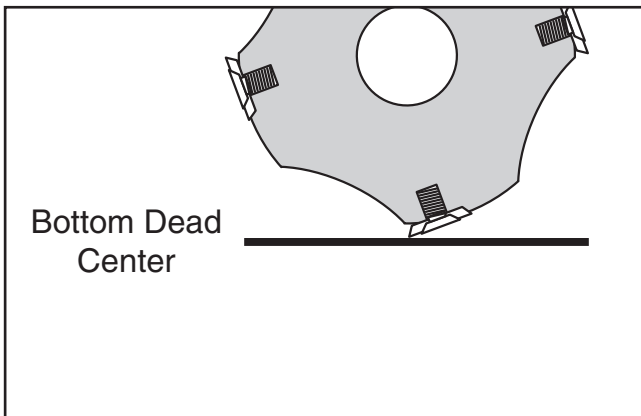

Figure 28. Cutter edge at bottom dead center.

To ensure accurate results and make the adjustment process quicker and easier, we recommend using a Rotacator (see **Page 20**) for these adjustments.

If a Rotacator is not available, a pair of even-sized wood blocks and a 0.40" feeler gauge can be used, but care must be taken to achieve accurate results.

To set the height of the infeed and outfeed rollers and the chip breaker using a Rotacator:

1. DISCONNECT THE PLANER FROM THE POWER SOURCE!

2. Lower the table at least 4" below the head casting and lock the table in place.
3. Remove the dust port, top cover, and belt cover.
4. Using a Rotacator, find BDC of any carbide insert edge by slowly rocking the cutterhead pulley back and forth, and set the Rotacator dial to zero, as shown in **Figure 29**.

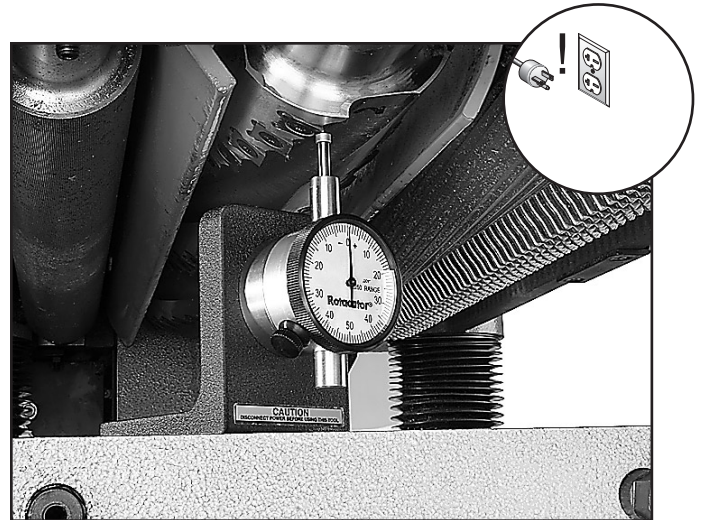

Figure 29. Example of finding BDC with the Rotacator.

5. Move the feed speed knob to neutral to allow the infeed roller to rotate by hand.
6. Place the Rotacator under the right-hand side of the infeed roller and find bottom dead center on a serrated edge by rocking the infeed roller back and forth.
7. Adjust the height of the infeed roller on the same side as the Rotacator to the specification given at the beginning of this procedure, using the zero setting of the Rotacator as a reference point. **Figure 30** shows the jam nut and set screw for adjusting the roller height.
8. Repeat **Steps 6 & 7** on the left-hand side of the infeed roller.
9. Double-check and micro-adjust both sides of the infeed roller, then carefully lock both sides in place.



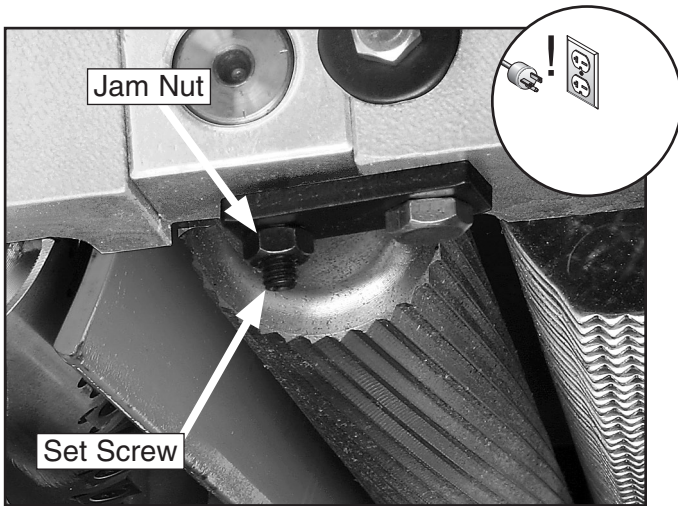

Figure 30. Roller height adjustment controls.

10. Using the same zeroed reference on the Rotacator, adjust the height of the chip breaker and outfeed roller to their given specifications. The adjustment controls for each are shown in **Figure 31**.

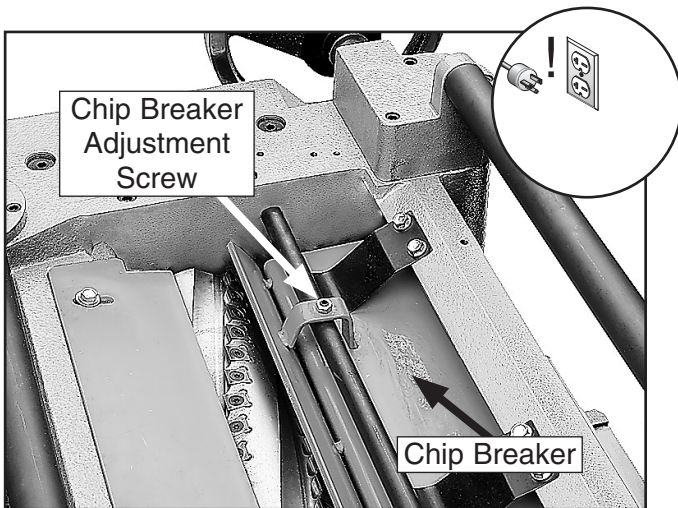

Figure 31. Adjustment locations for the chip breaker.

To adjust the height of the infeed and outfeed rollers, and the chip breaker using wood blocks and a feeler gauge:

1. Make the wood blocks by cutting a STRAIGHT 6' long 2x4 in half.

Note: Having the wood blocks at an even height is critical to the accuracy of your overall adjustments. For best results, remove board warpage by squaring the narrow sides of the 2x4 with a jointer and table saw before cutting in half.

2. DISCONNECT THE PLANER FROM THE POWER SOURCE!
3. Lower the bed rollers below the table.
4. Place one wood block along the left side of the table, and place the other wood block along the right side of the table, as illustrated in **Figure 32**.

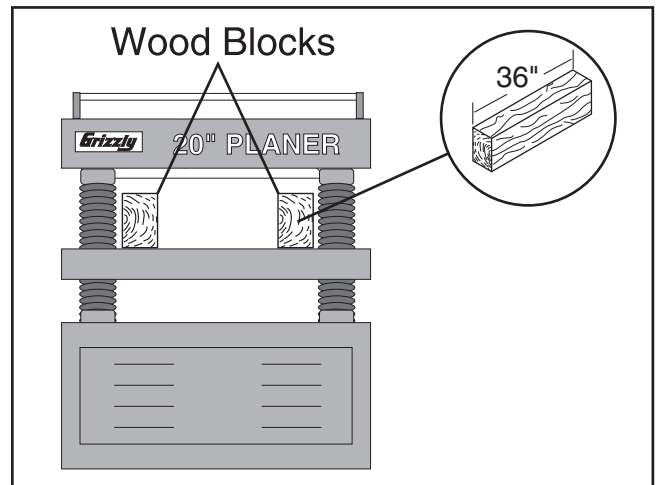

Figure 32. Wood blocks on table.

5. Remove the dust port, top cover and belt cover.
6. Adjust the table and use the feeler gauge until you have a 0.040" gap between the edge of a carbide insert at bottom dead center (find by rocking cutterhead pulley) and the wood blocks.



7. Lock the table height in place, as the wood blocks will now be your reference points for the rest of the adjustments.
8. Loosen the feed roller adjustment screws (**Figure 30**) and turn the adjustment bolts on each end to raise the feed roller above the wood block (if necessary), then bring it back down so it just touches the wood block on both sides.
9. Lock the infeed roller adjustment screws in place with the jam nuts, making sure they do not move while tightening.
10. Without moving the table, adjust the chip breaker and outfeed roller in the same manner, using the wood blocks as your reference point.
11. When you are finished with the adjustments, replace the top cover, dust port and belt cover.

Spring Tension

Tools Needed:	Qty
5mm Hex Wrench.....	1

Roller spring tension must be adjusted so that roller pressure is uniform.

To adjust roller spring tension:

1. Locate the four adjustment screws located on the top of the planer, as shown **Figure 33**.
2. Adjust screws #1–#3 so that they protrude $\frac{1}{8}$ " above the head casting.
3. Adjust screw #4 so that it protrudes $\frac{5}{16}$ " above the head casting.

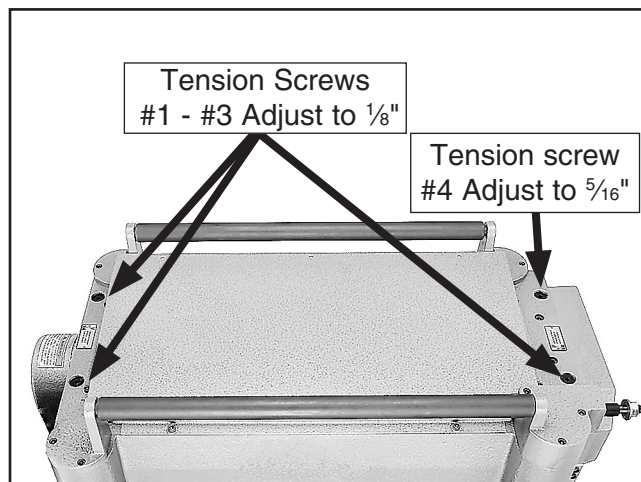

Figure 33. Tension screw locations and adjustments.



Chip Deflector Positioning

Chip Deflector Gap Setting	Qty
If Planer Used w/Dust Collector	1/4"
If Planer Used w/o Dust Collector	1/16"

Tools Needed:	Qty
Wrench or Socket 10mm	1
Hex Wrench 5mm	1

The chip deflector keeps chips from falling onto the outfeed roller.

To adjust the deflector position:

1. DISCONNECT THE PLANER FROM THE POWER SOURCE!
2. Remove the dust port and top cover.
3. Loosen the chip deflector mounting bolts (see **Figure 34**).

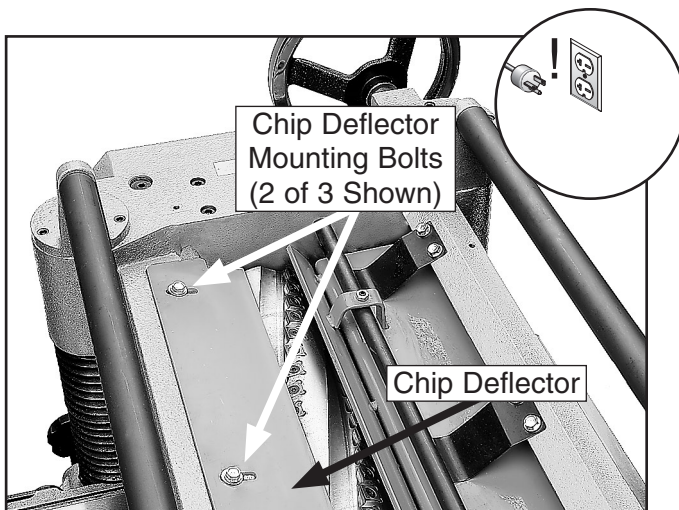

Figure 34. Chip deflector and mounting bolts.

4. Make sure the deflector is beveled toward the cutterhead. Move the deflector until the edge is the correct distance (given above) from the closest carbide insert. Use the cutterhead pulley to rotate the cutterhead to ensure clearance.
5. Re-tighten the mounting bolts and return the top cover to the planer.

Scale Calibration

Tools Needed:	Qty
Phillisp Screwdriver	1
Calipers	1

The scale can be adjusted for accuracy. The machine will need to be run to make proper adjustments.

To calibrate the scale:

1. Set the table to the approximate thickness of your test lumber. Measure the lumber with calipers to determine its exact thickness.
2. Move the table to 1/16" under the thickness of your lumber and feed your test board through the planer.
3. Turn the handwheel one full rotation and run the board through once more. Turn the board over and repeat.
4. Re-measure the board and compare your results with the scale. If there is a discrepancy, loosen the screw (see **Figure 35**) and adjust as necessary.



Figure 35. Depth scale adjustment screw.



Anti-Kickback Fingers

The Model G1021X provides an anti-kickback system as a safety feature. The anti-kickback fingers hang from a rod suspended across the cutterhead casting. The anti-kickback fingers should be inspected regularly.

Check the fingers (**Figure 36**) to ensure that they swing freely and easily. If the fingers do not swing freely and easily, clean them with a wood resin solvent.

Do not apply oil or other lubricants to the anti-kickback fingers. Oil or grease will attract dust, restricting the free movement of the fingers.

! WARNING

Proper operation of the anti-kickback fingers are essential for the safe operation of this machine. Failure to ensure that they are working properly could result in serious operator injury.

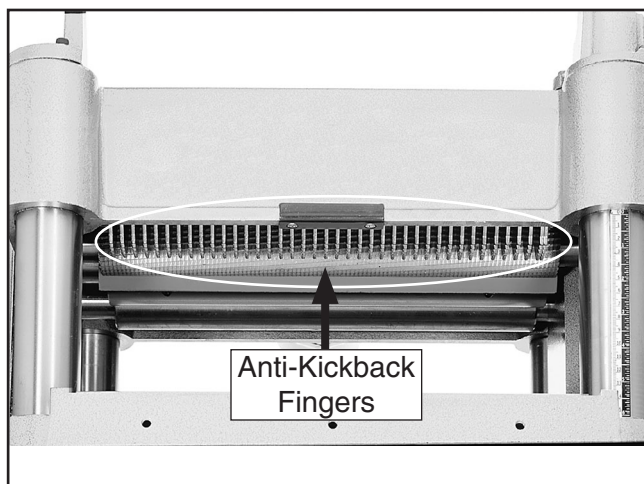

Figure 36. Anti-kickback fingers.

Pulley Alignment

Tools Needed:	Qty
Straightedge	1
Wrench 17mm	2
Wrench 14mm	2
Phillips Screwdriver #2	1

Proper pulley alignment (see **Figure 37**) prevents premature belt wear. The pulleys are properly aligned when they are parallel and in the same plane as each other. Use a straightedge on the edge of the pulleys to judge alignment.

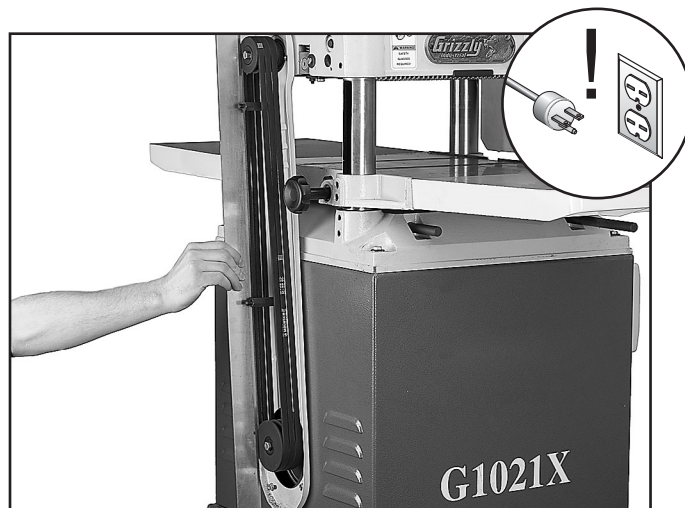

Figure 37. Checking belt alignment.

Should you find that the pulleys are out of alignment:

1. DISCONNECT THE PLANER FROM THE POWER SOURCE!
2. Loosen the belt tension.
3. Loosen the four motor mount bolts just enough to allow the motor to be repositioned.
4. Slide the motor as required to align the pulleys.
5. Re-tighten the motor mount bolts carefully to assure that the tightening process does not move the motor.
6. Re-tension the belt.
7. Replace the belt cover.



Troubleshooting Guide

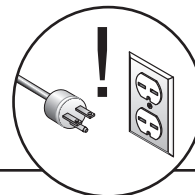

Motor & Machine Operation

Symptom	Possible Cause	Possible Solution
Motor will not start.	<ol style="list-style-type: none"> 1. Thermal overload relay inside magnetic switch has tripped. 2. Low voltage. 3. Open circuit in motor or loose connections. 	<ol style="list-style-type: none"> 1. Press the RESET button on the thermal overload relay; investigate reason it tripped to prevent future problems. 2. Check power line for proper voltage. 3. Inspect all lead connections on motor for loose or open connections.
Fuses or circuit breakers blow.	<ol style="list-style-type: none"> 1. Short circuit in line cord or plug. 	<ol style="list-style-type: none"> 1. Repair or replace cord or plug for damaged insulation and shorted wires.
Motor fails to develop full power (output of motor decreases rapidly with decrease in voltage at motor terminals).	<ol style="list-style-type: none"> 1. Power line overloaded with lights, appliances, and other motors. 2. Undersized wires or circuits too long. 3. Motor run capacitor at fault. 	<ol style="list-style-type: none"> 1. Reduce load on power line. 2. Increase wire sizes or reduce length of the circuit. 3. Replace run capacitor.
Motor overheats.	<ol style="list-style-type: none"> 1. Motor overloaded during operation. 2. Air circulation through the motor restricted. 	<ol style="list-style-type: none"> 1. Reduce cutting load; take lighter cuts. 2. Clean out motor to provide normal air circulation.
Motor stalls or shuts off during a cut.	<ol style="list-style-type: none"> 1. Motor overloaded during operation. 2. Thermal overload protection tripped in magnetic switch. 3. Short circuit in motor or loose connections. 4. Circuit breaker tripped. 	<ol style="list-style-type: none"> 1. Reduce cutting load; take lighter cuts. 2. Press the RESET button on the thermal overload relay, located inside the magnetic switch. 3. Repair or replace connections on motor for loose or shorted terminals or worn insulation. 4. Install correct circuit breaker; reduce # of machines running on that circuit.
Cutterhead slows or squeals when cutting, especially on start-up.	<ol style="list-style-type: none"> 1. V-belt(s) loose. 2. V-belt(s) worn out. 	<ol style="list-style-type: none"> 1. Tighten V-belts (Page 22). 2. Replace V-belt(s) (Page 22).
Loud repetitious noise coming from machine.	<ol style="list-style-type: none"> 1. Pulley set screws or keys are missing or loose. 2. Motor fan is hitting the cover. 3. V-belt(s) damaged. 	<ol style="list-style-type: none"> 1. Inspect keys and set screws. Replace or tighten if necessary. 2. Adjust fan cover mounting position, tighten fan, or shim fan cover. 3. Replace V-belts (Page 22).
Vibration when running or cutting.	<ol style="list-style-type: none"> 1. Loose or damaged blade. 2. Damaged V-belt(s). 3. Worn cutterhead bearings. 	<ol style="list-style-type: none"> 1. Tighten or replace blade. 2. Replace V-belt(s). 3. Check/replace cutterhead bearings.

Table

Symptom	Possible Cause	Possible Solution
Table is hard to adjust.	<ol style="list-style-type: none"> 1. Table lock is engaged or partially engaged. 2. Drive chain is dirty. 	<ol style="list-style-type: none"> 1. Completely loosen the table lock. 2. Clean and lubricate the drive chain (see Page 22 and Page 25).



Cutting

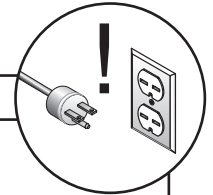

Symptom	Possible Cause	Possible Solution
<p>Excessive snipe (gouge in the end of the board that is uneven with the rest of the cut).</p> <p>Note: A small amount of snipe is inevitable with all types of planers. The key is minimizing it as much as possible.</p>	<ol style="list-style-type: none"> One or both of the bed rollers are set too high. Outfeed extension table set too low. Chipbreaker set too low. Workpiece is not supported as it leaves the planer. 	<ol style="list-style-type: none"> Lower the bed rollers (Page 19). Raise the outfeed extension table (Page 14); sometimes raising outfeed extension table slightly higher than the table helps. Raise the height of the chipbreaker (Page 27). Hold the workpiece up slightly as it leaves the outfeed end of the planer.
Workpiece stops/slows in the middle of the cut.	<ol style="list-style-type: none"> Taking too heavy of a cut. One or both of the bed rollers are set too low or too high. Chipbreaker set too low. Feed rollers set too low or too high. Table not parallel with head casting. Pitch and glue build up on planer components. 	<ol style="list-style-type: none"> Take a lighter cut. Lower/raise the bed rollers (Page 19). Raise height of chipbreaker (Page 27). Adjust the feed rollers to the correct height (Page 27) Adjust the table so it is parallel to the head casting. Clean the internal cutterhead components with a pitch/resin dissolving solvent.
Chipping (consistent pattern).	<ol style="list-style-type: none"> Knots or conflicting grain direction in wood. Nicked or chipped carbide cutter. Feeding workpiece too fast. Taking too deep of a cut. Misaligned chipbreaker. 	<ol style="list-style-type: none"> Inspect workpiece for knots and grain direction; only use clean stock. Rotate or replace the affected cutter (Page 24). Slow down the feed rate (Page 18). Take a smaller depth of cut. (Always reduce cutting depth when surface planing or working with hard woods.) Adjust both sides of the chipbreaker to the correct height (Page 27).
Fuzzy grain.	<ol style="list-style-type: none"> Wood may have high moisture content or surface wetness. Dull cutters. 	<ol style="list-style-type: none"> Check moisture content and allow to dry if moisture is too high. Rotate/replace the cutters (Page 24).
Long lines or ridges that run along the length of the board	<ol style="list-style-type: none"> Nicked or chipped cutter(s). 	<ol style="list-style-type: none"> Rotate/replace the cutters (Page 24).
Uneven cutter marks, wavy surface, or chatter marks across the face of the board.	<ol style="list-style-type: none"> Feeding workpiece too fast. Chipbreaker set unevenly. Carbide cutters not evenly installed. Worn cutterhead bearings. 	<ol style="list-style-type: none"> Slow down the feed rate. Adjust the height of the chipbreaker (Page 27). Make sure carbide cutters do not have debris under them; make sure cutters are torqued down evenly. Replace cutterhead bearings.
Glossy surface.	<ol style="list-style-type: none"> Carbide cutters are dull. Feed rate too slow. Cutting depth too shallow. 	<ol style="list-style-type: none"> Rotate/replace the cutters (Page 24). Increase the feed rate (Page 18). Increase the depth of cut.
Chip Marks (inconsistent pattern).	<ol style="list-style-type: none"> Chips aren't being properly expelled from the cutterhead. 	<ol style="list-style-type: none"> Use a dust collection system; adjust the chip deflector in or out depending on your setup (Page 30).



Electrical Components

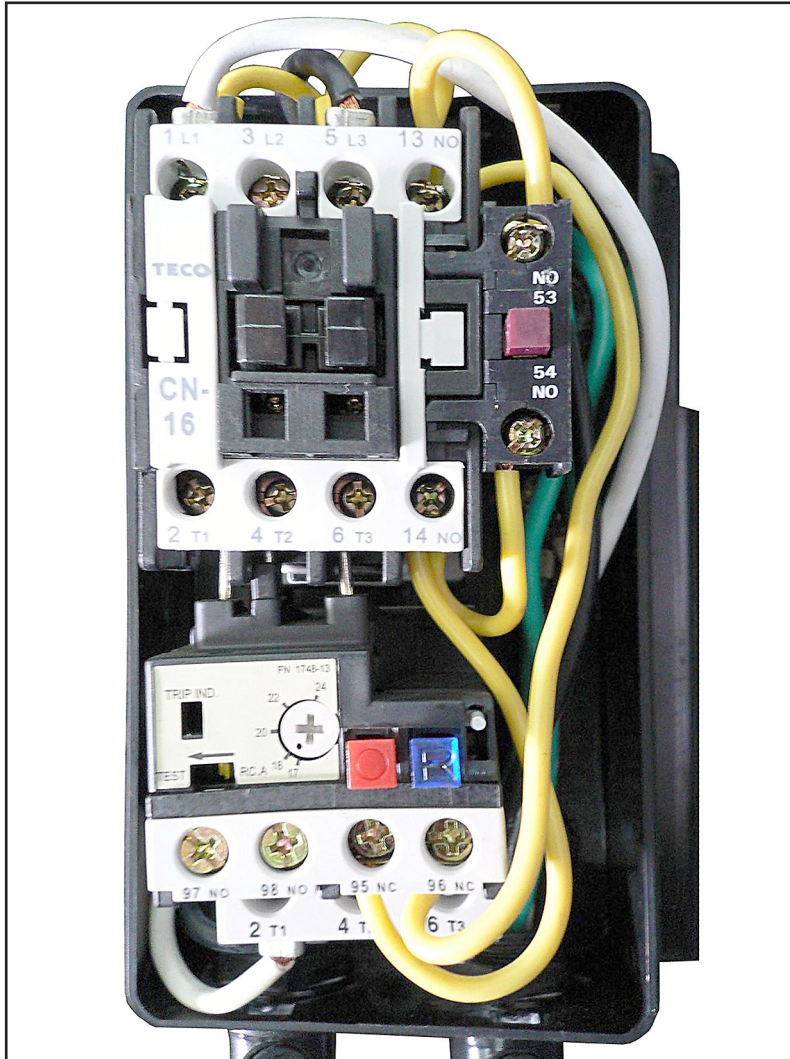

Figure 38. Magnetic Switch.



Figure 39. Motor Junction Box.



Wiring Diagram



MODEL G1021X

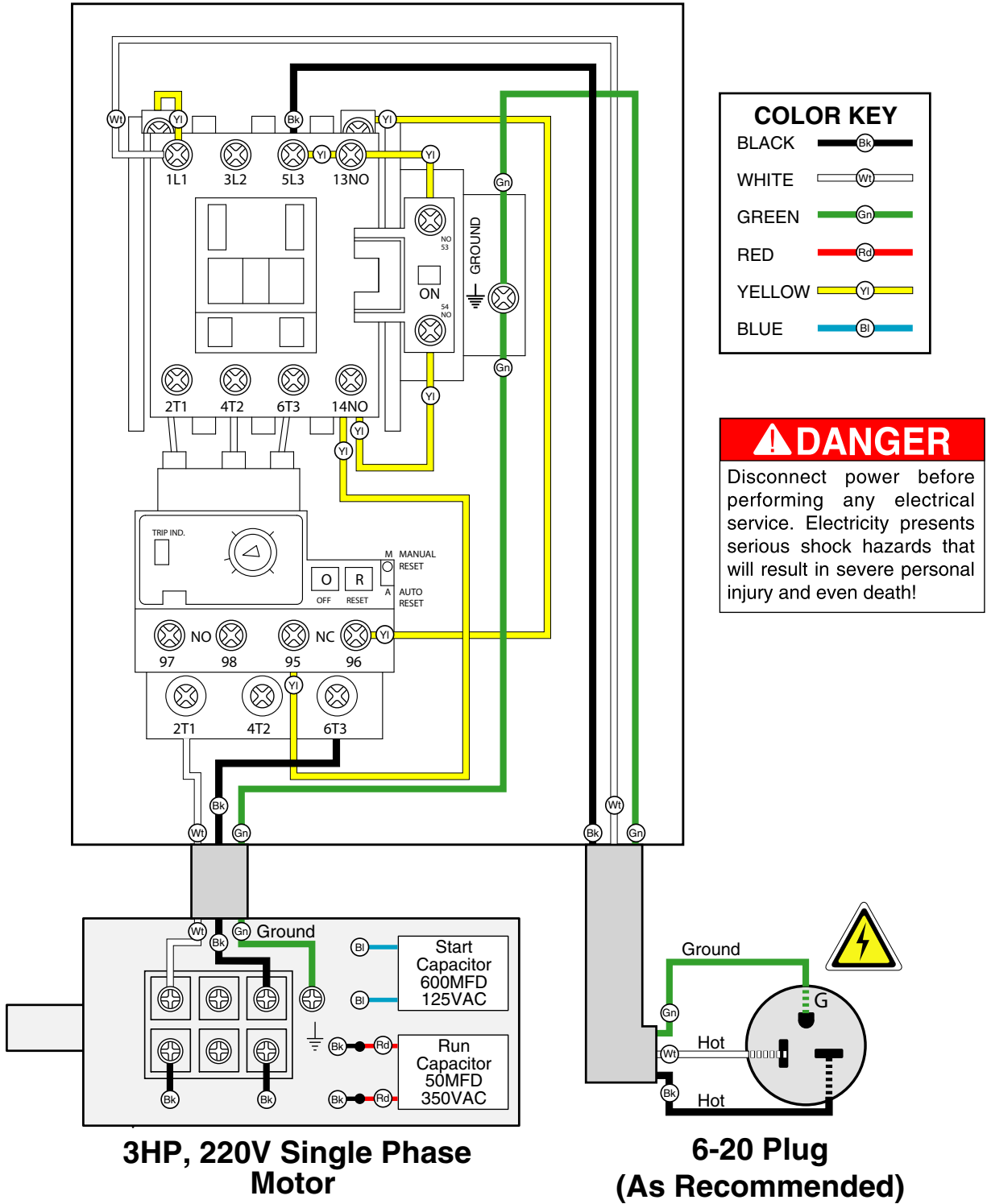
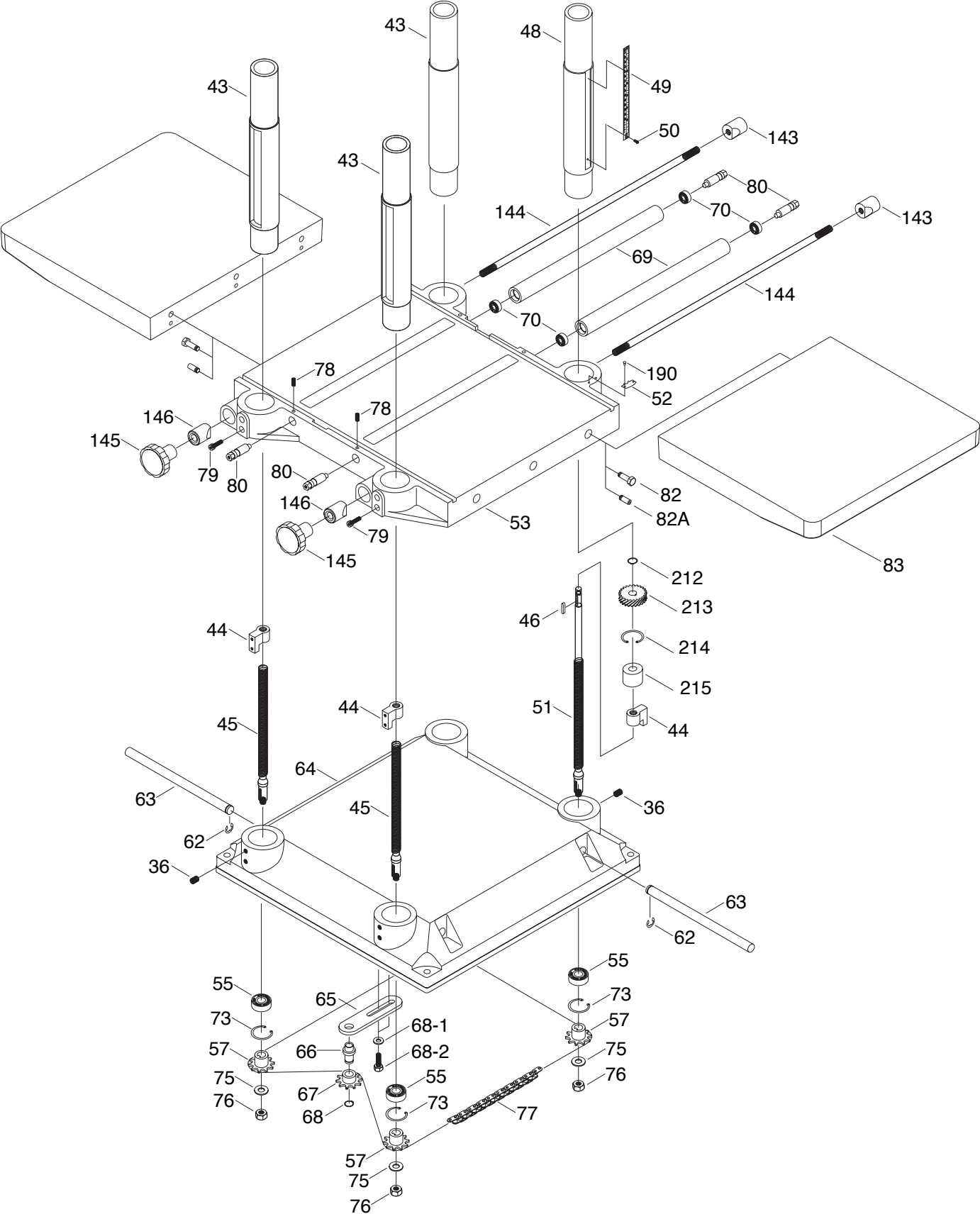
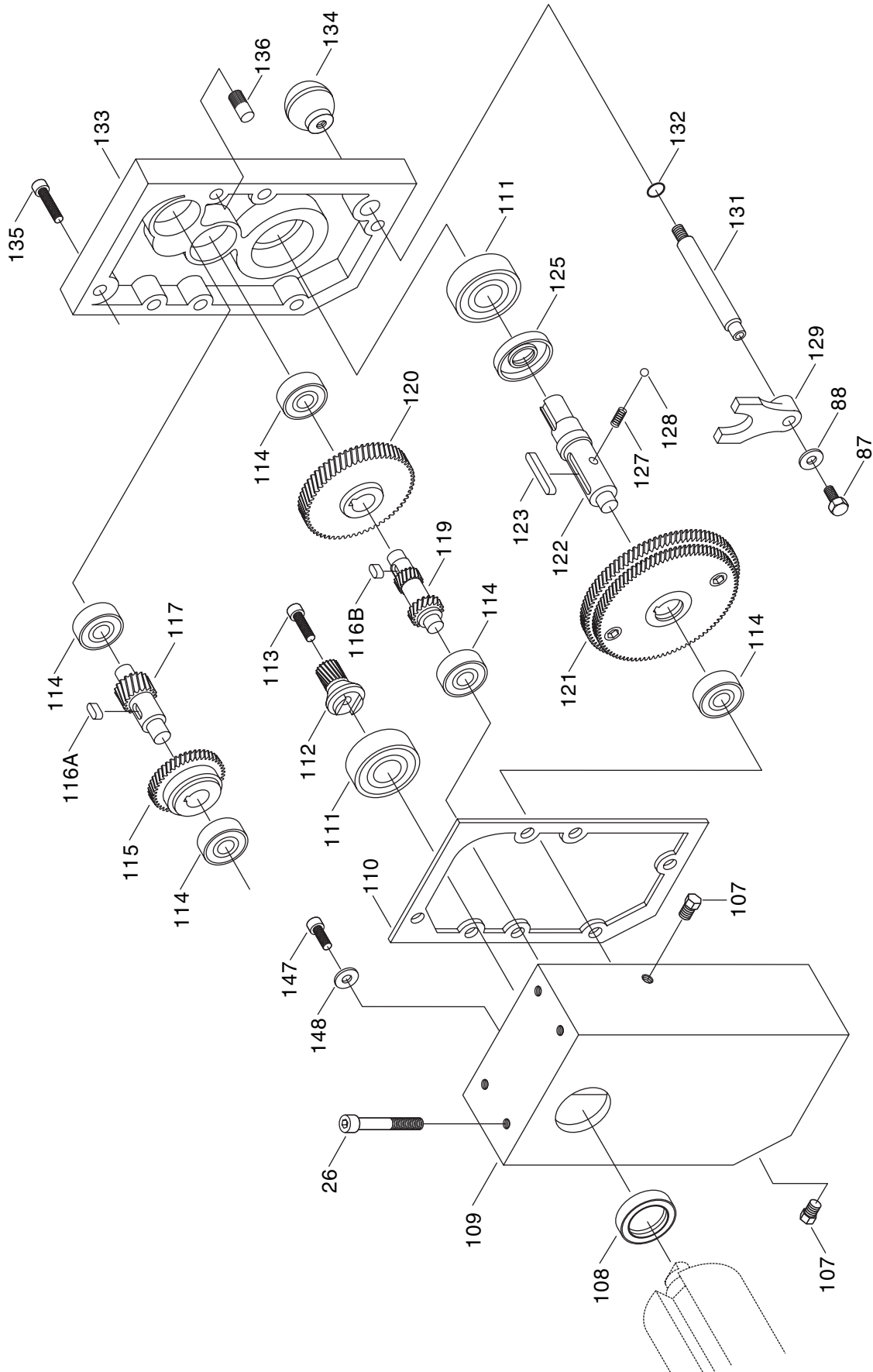

Table and Base Breakdown



Internal Gearbox Breakdown



External Gearbox Breakdown

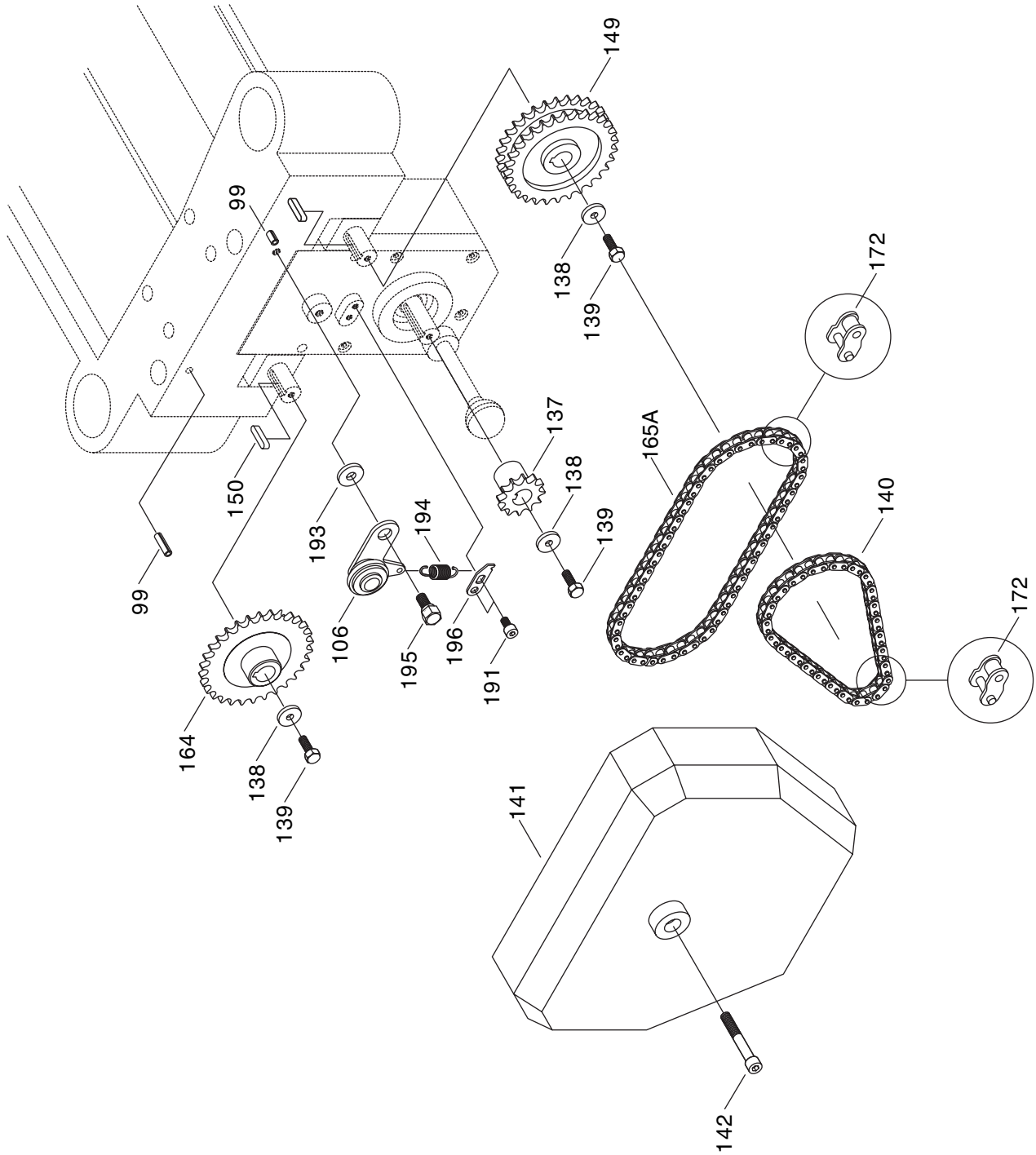

Stand and Motor Breakdown

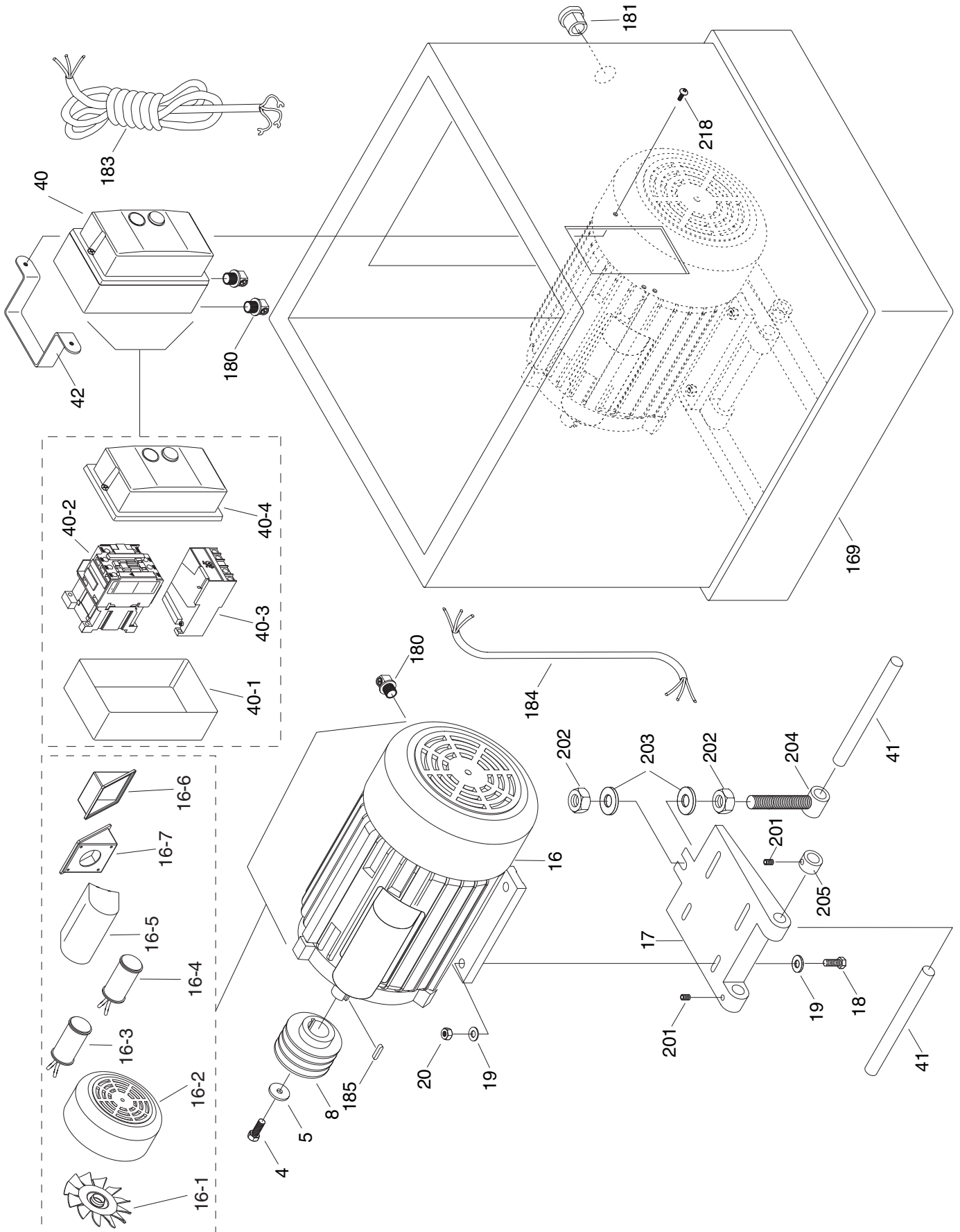

Label Placement

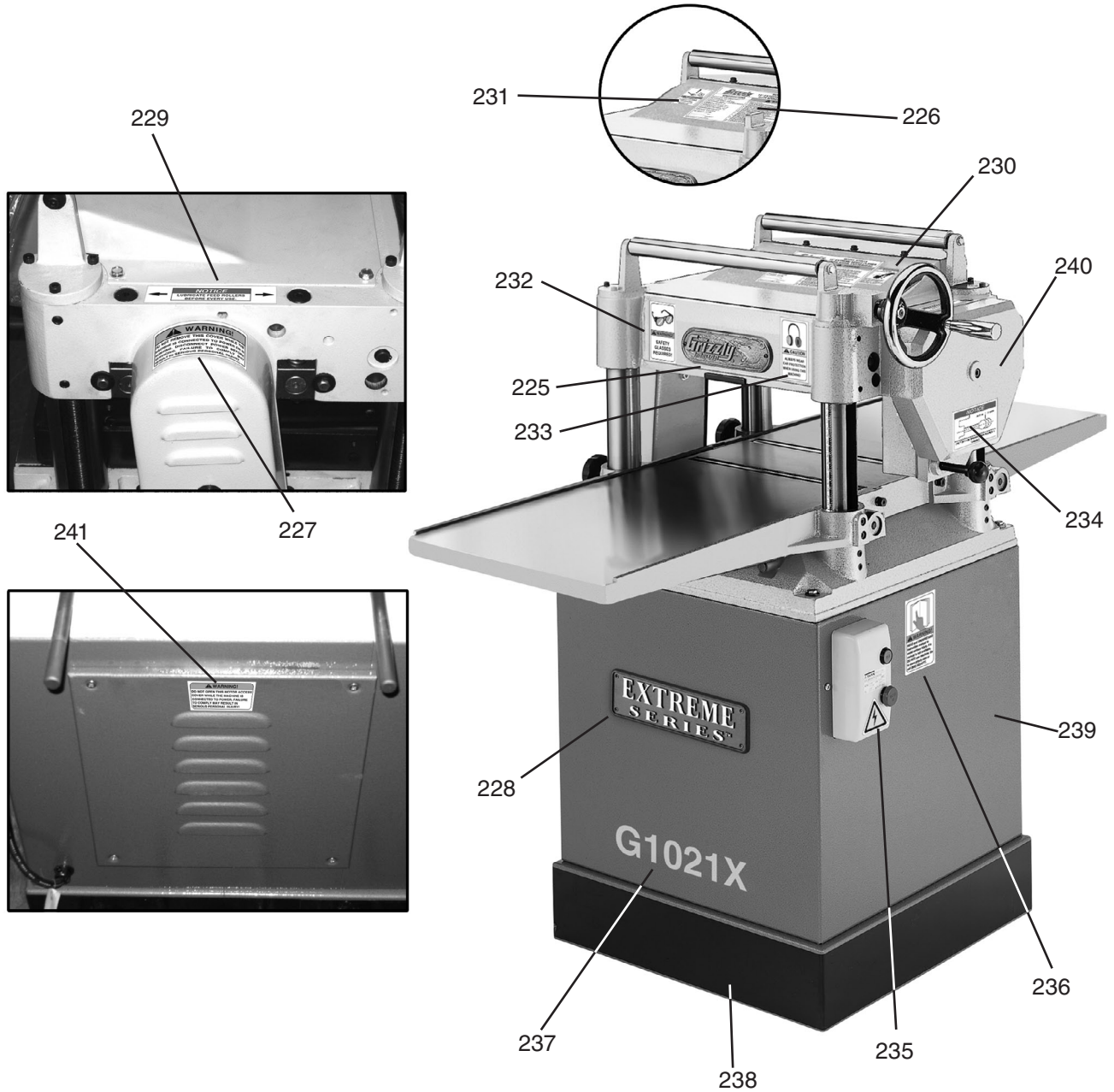

WARNING

Safety labels warn about machine hazards and ways to prevent injury. The owner of this machine **MUST** maintain the original location and readability of the labels on the machine. If any label is removed or becomes unreadable, **REPLACE** that label before using the machine again. Contact Grizzly at (800) 523-4777 or www.grizzly.com to order new labels.



Parts List

REF	PART #	DESCRIPTION
1	P1033084	PULLEY COVER
2	PFB01M	FLANGE BOLT M6-1 X 12
3	PVM59	V-BELT M-59 3L590
4	PB07M	HEX BOLT M8-1.25 X 25
5	P1021005	SPECIAL WASHER
6	P1033085	KNOB 5/16"-18
7	P1021007	CUTTERHEAD PULLEY
8	P1021008	MOTOR PULLEY
12	P1033080	STUD
13	P1033079	PULLEY GUARD
14	PB02M	HEX BOLT M6-1 X 12
15	PW03M	FLAT WASHER 6MM
16	P1021X016	MOTOR 3HP 220V SINGLE PHASE
16-1	P1021X016-1	MOTOR FAN
16-2	P1021X016-2	MOTOR FAN COVER
16-3	P1021X016-3	START CAPACITOR 600 MFD 125VAC
16-4	P1021X016-4	RUN CAPACITOR 50 MFD 350VAC
16-5	P1021X016-5	CAPACITOR COVER
16-6	P1021X016-6	MOTOR JUNCTION BOX COVER
16-7	P1021X016-7	MOTOR JUNCTION BOX
17	P1021Z017	MOTOR PLATE
18	PB14M	HEX BOLT M8-1.25 X 35
19	PW01M	FLAT WASHER 8MM
20	PN03M	HEX NUT M8-1.25
21	P1021Z021	WORM GEAR BOX
21-1	P1021Z021-1	ROLLER STAND
22	P1021Z022	HEAD CASTING
23	P1021023	CHIP DEFLECTOR
25	P1021025	TENSIONING SETSCREW
26	PSB05M	CAP SCREW M8-1.25 X 50
27	PSS11M	SETSCREW M6-1 X 16
28	P1021028	CHIP BREAKER SPRING
30	PN08M	HEX NUT M10-1.25
31	PW04M	FLAT WASHER 10MM
31A	P1021031A	DIRECTION SCALE
32	P1021032	HANDLE
33	P1021033	HEIGHT HANDWHEEL
34	PR22M	INT RETAINING RING 38MM
35	P1021035	BUSHING
36	PSS13M	SETSCREW M10-1.5 X 12
38	PSB26M	CAP SCREW M6-1 X 12
40	P1021Z040	3HP MAGNETIC SWITCH ASSEMBLY
40-1	P1021X40-1	SWITCH COVER (REAR)
40-2	P1021X40-2	CONTACTOR 220V
40-3	P1021X40-3	THERMAL RELAY

REF	PART #	DESCRIPTION
40-4	P1021X40-4	SWITCH COVER (FRONT)
41	P1021Z041	MOUNTING SHAFT
42	P1021Z042	SWITCH MOUNT BRACKET
43	P1021043	COLUMN
44	P1021044	SPINDLE NUT
45	P1021045	ELEV. LEAD SCREW, SHORT
46	PK48M	KEY 4 X 4 X 20
48	P1021048	COLUMN W/ SCALE SLOT
49	P1021049	SCALE
50	PS12M	PHLP HD SCREW M3-0.5 X 6
51	P1021Z051	ELEVATION SPINDLE, LONG
52	P1021052	POINTER
53	P1021053	TABLE
55	P6202	BEARING 6202-2RS
57	P1021057	SPROCKET
62	PEC05M	E-CLIP 15MM
63	P1021063	LIFTING HANDLE
64	P1021064	BASE
65	P1021065	IDLER BRACKET
66	P1021066	SHAFT
67	P1021067	IDLER SPROCKET
68	PR02M	EXT RETAINING RING 14MM
68-1	PW01M	FLAT WASHER 8MM
68-2	PB07M	HEX BOLT M8-1.25 X 25
69	P1021069B	TABLE ROLLER
70	P608	BEARING 608-2RS
73	PR21M	EXT RETAINING RING 35MM
75	PW04M	FLAT WASHER 10MM
76	PN02M	HEX NUT M10-1.5
77	P1021077	CHAIN
78	PSS04M	SETSCREW M6-1 X 12
79	PSB02M	CAP SCREW M6-1 X 20
80	P1021080	TABLE ROLLER SHAFT
82	PB07M	HEX BOLT M8-1.25 X 25
82A	PSS14M	SETSCREW M8-1.25 X 20
83	P1021X083	EXTENSION TABLE
87	PB02M	HEX BOLT M6-1 X 12
88	PW03M	FLAT WASHER 6MM
90	PSS11M	SETSCREW M6-1 X 16
90-1	PN01M	HEX NUT M6-1
91	PB09M	HEX BOLT M8-1.25 X 20
92	P1021092	PLATE
94	PSS14M	SETSCREW M8-1.25 X 12
97	P1021Z097	UPPER COVER
99	PRP07M	ROLL PIN 6 X 20



REF	PART #	DESCRIPTION
100	P6205	BEARING 6205-2RS
101	PK41M	KEY 8 X 8 X 40
102	P1021X102	SPIRAL CUTTERHEAD 15"
106	P1033099	CHAIN TENSIONER
107	P1021107	OIL PLUG
108	P1021108	OIL SEAL 28 X 40 X 8
109	P1021Z109	GEAR BOX
110	P1021110	GASKET
111	P6204	BEARING 6204-2RS
112	P1021112	GEAR
113	PSB02M	CAP SCREW M6-1 X 20
114	P6201	BEARING 6201-2RS
115	P1021115	GEAR
116A	PK10M	KEY 5 X 5 X 12
116B	PK06M	KEY 5 X 5 X 10
117	P1021117	GEAR AND SHAFT
119	P1021119	GEAR, 2 SPEED
120	P1021120	GEAR
121	P1021121	DOUBLE GEAR
122	P1021122	SHAFT
123	PK11M	KEY 6 X 6 X 40
125	P1021125	OIL SEAL 25 X 47 X 7
127	P1021127	COMPRESSION SPRING
128	P1021128	BALL 6MM
129	P1021129	SHIFTER
131	P1021131	SHIFTING HANDLE
132	P0550109	O-RING 12MM
133	P1021Z133	GEAR CASE COVER
134	P1021134	KNOB M12-1.75
135	PSB06M	CAP SCREW M6-1 X 25
136	P1021X136	GEARBOX MOUNTING ROD
137	P1021137	SPROCKET
138	P1021138	SPECIAL WASHER
139	PB18M	HEX BOLT M6-1 X 25
140	P1021140	CHAIN, 23 LINKS
141	P1021Z141	CHAIN COVER
142	PSB05M	CAP SCREW M8-1.25 X 50
143	P1021143	THREADED GIB
144	P1021144	LOCKING ROD
145	P1021145	LOCKING KNOB M12-1.75
146	P1021146	GIB
147	PSB01M	CAP SCREW M6-1 X 16
148	PW03M	FLAT WASHER 6MM
149	P1021149	SPROCKET

REF	PART #	DESCRIPTION
150	PK21M	KEY 5 X 5 X 23
151	P1021151	OUTFEED ROLLER
152	P1021152	SPRING
153	P1021153	BUSHING BLOCK
154	P1021154	CHIPBREAKER
155	PN01M	HEX NUT M6-1
156	PSS11M	SET SCREW M6-1 X 16
157	P1021157	CHIPBREAKER ADJUST ROD
159	PEC05M	E-CLIP 15MM
160	P1021160	SPACER
161	P1021161	ANTI-KICKBACK FINGER
162	P1021162	SHAFT
163	P1021163	INFEED ROLLER
164	P1021164	SPROCKET
165A	P1021165A	CHAIN, 31 LINKS
167	PWR810	WRENCH, 8 X 10
167-1	PWR1214	WRENCH, 12 X 14
168	P1021Z168	CHIP CHUTE
169	P1021Z169	STAND
170	PH7653002	INDEXABLE CUTTER 14 x 14 x 2
171	PFH15M	FLAT HD TORX SCR T20 M6-1 x 15
172	PHL01	REPLACEMENT HALF LINK
174	P1021174	DEPTH LIMITER
175	PFH05M	FLAT HD SCR M5-.8 X 12
176	P1033097	RETAINER
177	PR03M	EXT RETAINING RING 12MM
178	P1021178	PIVOT ROD
179	PN09M	HEX NUT M12-1.75
180	P1021180	STRAIN RELIEF
181	P1021Z181	STRAIN RELIEF
182	PLW03M	LOCK WASHER 6MM
183	PWRCRD220L	POWER CORD 220V, LONG, 10AWG
184	PWRCRD220S	POWER CORD 220V, SHORT, 16AWG
185	PK15M	KEY 5 X 5 X 35
186	PAW03M	HEX WRENCH 3MM
187	PAW04M	HEX WRENCH 4MM
188	PAW05M	HEX WRENCH 5MM
189	PAW06M	HEX WRENCH 6MM
190	G1021050A	RIVET
191	PSB04M	CAP SCREW M6-1 X 10
193	P1033105	SPACER
194	P1033104	EXTENSION SPRING
195	P1033102	SHAFT
196	P1033103	HANGER



REF	PART #	DESCRIPTION
201	PSS01M	SET SCREW M6-1 X 10
202	PN08M	HEX NUT M10-1.25
203	PW04M	FLAT WASHER 10MM
204	P1021Z204	PIVOT STUD
205	P1021Z205	COLLAR
206	P1021Z206	SHAFT
207	P608	BALL BEARING 608ZZ
208	P1021Z208	SHAFT WITH GEAR
209	PK05M	KEY 4 X 4 X 10
210	P6200	BALL BEARING 6200
211	P1021Z211	ROLLER SHAFT
212	PEC03M	E-CLIP 10MM
213	P1021Z213	GEAR
214	PR23M	INT RETAINING RING 40MM
215	P1021Z215	SPACER
218	PS14M	PHLP HD SCR M6-1 X 12
219	PW07	FLAT WASHER 5/16"
220	PN02	HEX NUT 5/16"-18
223	PH7653014	T-HANDLE DRIVER 1/4"

REF	PART #	DESCRIPTION
224	PH7653015	TORX BIT T20
225	H4609	GRIZZLY NAMEPLATE
226	P1021X226	G1021X MACHINE ID LABEL
227	P1021Z217	BELT GUARD LABEL
228	P1021X228	EXTREME SERIES NAMEPLATE
229	P1021X229	FEED ROLLER OIL LABEL
230	P1021X230	CUTTERHEAD LABEL
231	P1021X231	UNPLUG LABEL
232	PLABEL-11	SAFETY GLASSES 2" X 3-5/16"
233	PLABEL-15	EAR PROTECTION 2" X 3-5/16"
234	P1021X234	GEAR LEVER LABEL
235	PLABEL-14	ELECTRICITY LABEL
236	PLABEL-12A	READ MANUAL 2" X 3-5/16"
237	P1021X237	G1021X MODEL NUMBER LABEL
238	P1021Z223	BLACK TAPE 110MM X 2200MM
239	P1021X239	TOUCH-UP PAINT GREEN
240	P1021X240	TOUCH-UP PAINT BEIGE
241	P1021X241	MOTOR ACCESS LABEL



Notes



WARRANTY AND RETURNS

Grizzly Industrial, Inc. warrants every product it sells for a period of **1 year** to the original purchaser from the date of purchase. This warranty does not apply to defects due directly or indirectly to misuse, abuse, negligence, accidents, repairs or alterations or lack of maintenance. This is Grizzly's sole written warranty and any and all warranties that may be implied by law, including any merchantability or fitness, for any particular purpose, are hereby limited to the duration of this written warranty. We do not warrant or represent that the merchandise complies with the provisions of any law or acts unless the manufacturer so warrants. In no event shall Grizzly's liability under this warranty exceed the purchase price paid for the product and any legal actions brought against Grizzly shall be tried in the State of Washington, County of Whatcom.

We shall in no event be liable for death, injuries to persons or property or for incidental, contingent, special, or consequential damages arising from the use of our products.

To take advantage of this warranty, contact us by mail or phone and give us all the details. We will then issue you a "Return Number," which must be clearly posted on the outside as well as the inside of the carton. We will not accept any item back without this number. Proof of purchase must accompany the merchandise.

The manufacturers reserve the right to change specifications at any time because they constantly strive to achieve better quality equipment. We make every effort to ensure that our products meet high quality and durability standards and we hope you never need to use this warranty.

Please feel free to write or call us if you have any questions about the machine or the manual.

Thank you again for your business and continued support. We hope to serve you again soon.





WARRANTY CARD

Name _____
 Street _____
 City _____ State _____ Zip _____
 Phone # _____ Email _____ Invoice # _____
 Model # _____ Order # _____ Serial # _____

The following information is given on a voluntary basis. It will be used for marketing purposes to help us develop better products and services. **Of course, all information is strictly confidential.**

1. How did you learn about us?

Advertisement Friend Catalog
 Card Deck Website Other:

2. Which of the following magazines do you subscribe to?

<input type="checkbox"/> Cabinet Maker	<input type="checkbox"/> Popular Mechanics	<input type="checkbox"/> Today's Homeowner
<input type="checkbox"/> Family Handyman	<input type="checkbox"/> Popular Science	<input type="checkbox"/> Wood
<input type="checkbox"/> Hand Loader	<input type="checkbox"/> Popular Woodworking	<input type="checkbox"/> Wooden Boat
<input type="checkbox"/> Handy	<input type="checkbox"/> Practical Homeowner	<input type="checkbox"/> Woodshop News
<input type="checkbox"/> Home Shop Machinist	<input type="checkbox"/> Precision Shooter	<input type="checkbox"/> Woodsmith
<input type="checkbox"/> Journal of Light Cont.	<input type="checkbox"/> Projects in Metal	<input type="checkbox"/> Woodwork
<input type="checkbox"/> Live Steam	<input type="checkbox"/> RC Modeler	<input type="checkbox"/> Woodworker West
<input type="checkbox"/> Model Airplane News	<input type="checkbox"/> Rifle	<input type="checkbox"/> Woodworker's Journal
<input type="checkbox"/> Modeltec	<input type="checkbox"/> Shop Notes	<input type="checkbox"/> Other:
<input type="checkbox"/> Old House Journal	<input type="checkbox"/> Shotgun News	

3. What is your annual household income?

\$20,000-\$29,000 \$30,000-\$39,000 \$40,000-\$49,000
 \$50,000-\$59,000 \$60,000-\$69,000 \$70,000+

4. What is your age group?

20-29 30-39 40-49
 50-59 60-69 70+

5. How long have you been a woodworker/metalworker?

0-2 Years 2-8 Years 8-20 Years 20+ Years

6. How many of your machines or tools are Grizzly?

0-2 3-5 6-9 10+

7. Do you think your machine represents a good value? Yes No

8. Would you recommend Grizzly Industrial to a friend? Yes No

9. Would you allow us to use your name as a reference for Grizzly customers in your area?
Note: We never use names more than 3 times. Yes No

10. Comments: _____

CUT ALONG DOTTED LINE

FOLD ALONG DOTTED LINE



Place Stamp Here



GRIZZLY INDUSTRIAL, INC.
P.O. BOX 2069
BELLINGHAM, WA 98227-2069



FOLD ALONG DOTTED LINE

Send a Grizzly Catalog to a friend:

Name _____
Street _____
City _____ State _____ Zip _____

TAPE ALONG EDGES--PLEASE DO NOT STAPLE

grizzly.com

TOOL WEBSITE

Buy Direct and Save with Grizzly® – Trusted, Proven and a Great Value!

*Visit Our Website Today And Discover
Why Grizzly® Is The Industry Leader!*

- SECURE ORDERING
- ORDERS SHIPPED WITHIN 24 HOURS
- E-MAIL RESPONSE WITHIN ONE HOUR

-OR-

Call Today For A **FREE**
Full Color Catalog

1-800-523-4777

